

Sim Racing Pedals Manual



Invicta™

**Thank you for purchasing the Asetek SimSports® Invicta™ pedals
T.H.O.R.P.™ II.**

You have made an excellent choice! We are sure the Invicta™ pedals will help you take your sim racing career to the next level. Whether you are a beginner or an experienced racer, you will now be able to reach ultimate immersion.

Prepare for the sensation of being in a real race car.

Table of contents

Foreword	2	4.2.8 Adjust the Brake Pedal Attack Point	24
About This Document	2	4.2.9 Swapping Elastomers	26
Other Relevant Documents	2	4.2.10 Elastomer Types	29
Symbols Used	3	4.2.11 Brake Pedal Preload Adjustment	30
Copyright	3	4.3 Connecting to your PC	33
1. Introduction	3	4.4 Start Racing!	34
1.1 Box Contents	4	5. RaceHub™ Adjustments	34
1.2 Videos	5	5.1 RaceHub™ Download	34
1.3 Manual version	5	5.1.1 RaceHub™ Installation	34
1.4 Support & Contact	5	5.1.2 RaceHub™ Updating	35
2. Product	5	5.2 Introduction	35
2.1 Intended Use	5	5.3 Pedal Calibration	35
2.2 Compatibility	6	5.4 Deadzone Adjustments	36
2.3 Reasonably Foreseeable Unintended Use	6	5.5 Maximum Brake Force Adjustment	37
2.4 General Specifications	6	5.6 Custom Pedal Mapping	38
3. Product Overview	7	6. Compatible Products	39
4. Getting Started	8	6.1 Asetek SimSports® Invicta™ Clutch	39
4.1 Installing your Pedals	8	6.2 Universal Footrest	40
4.1.1 Tools Required	8	7. Maintenance	41
4.1.2 Optional Tools	8	7.1 Throttle Maintenance	41
4.1.3 Mounting to your Rig	8	7.2 Brake Maintenance	41
4.2 Adjusting the Pedals	11	7.3 Spare Parts	41
4.2.1 Pedal Face Plate Adjustments	12	8. Troubleshooting	42
4.2.2 How Does the T.H.O.R.P.™ II System Function	13	9. Safety	43
4.2.3 Adjusting the Brake Pedal Angle	16	10. De-commissioning & Sustainability	44
4.2.4 Throttle Pedal Angle Adjustment	18	10.1 Packaging	44
4.2.5 Throttle Preload Adjustment	19	10.2 Product	44
4.2.6 Throttle Spring Replacement	21	10.3 Production	45
4.2.7 Throttle Travel Distance Adjustment	23	11. Declaration of Conformity	45

Foreword

About This Document

This manual is written for the end-user of the Asetek SimSports® Invicta™ Pedals T.H.O.R.P.™ II. (hereon after: “pedals”) and contains all information required to correctly and safely install, use and maintain the following models:

Model Name	P-BT-1
Product Name	Invicta™ Pedals T.H.O.R.P.™ II
Product Code	40-010-0000008

This manual was authored in English. All other languages are translations of the original document.

Please make sure that you have thoroughly read and understood all contents of this manual before installing, using, or performing maintenance on the pedals.

If anything in this manual is unclear, please contact Asetek SimSports® Support (available on www.asetek.com/simsports/support/).

Please note the serial number on your product before contacting the support. The serial number can be found on the bottom of the base plate and written here for your convenience:



Serial Number	
Asetek Denmark A/S Assensvej 2 9220 Aalborg East Denmark www.asetek.com	

Other Relevant Documents

These documents may assist you in your quest for faster lap times:

Mounting patterns, software, DoC, and other installation manuals can be found here:

<https://www.asetek.com/simsports/knowledge-base/>

Symbols Used

Make sure you pay attention to all warnings and symbols on the product and packaging.

Indicates that minor to moderate injuries may be sustained if the instruction is not followed correctly



This indicates that the product could be damaged if the instruction is not followed correctly



Copyright

The content of this manual is protected by copyright and other international intellectual property laws. The contents of this manual or any parts thereof may only be made public, copied, modified, reproduced, translated with express written permission from Asetek. This manual or any parts thereof may only be published, transmitted, displayed, or made available to a third party with express written permission from Asetek SimSports®.

1. Introduction

Thank you for purchasing the Asetek SimSports® Invicta™ Pedals T.H.O.R.P.™ II. We strongly encourage you to read through this manual thoroughly in its entirety. The Invicta™ pedals are a premium product made to fit each user. They have an excellent baseline adjustment out of the box, and we strongly encourage you to drive for 5+ hours with the baseline adjustments before changing anything. After that, your full immersion racing experience is unlocked when they are adjusted to your personal preference.

1.1 Box Contents

The box contains the following components and accessories:

- Invicta™ Pedals T.H.O.R.P.™ II Brake & Throttle pedal combo
- Safety information
- Warranty statement
- Asetek SimSports® sticker sheet
- USB Type-A to USB Type-C cable (Two (2) meters)
- USB Type-C to USB Type-C cable (Two (2) meters)
- Performance grease (2 ml)
- M6x20 bolt (x4)
- M6 Slot nut (x4)
- Washer (x4)
- M6 Hex nut (x4)
- Allen Key, 3mm
- Allen key, 5mm
- Long travel elastomer guide
- Elastomer
 - Extra-Soft, Extra
 - Soft, Extra
 - Medium, Extra
 - Hard, Preinstalled
 - Extra-Hard, Extra
- Throttle Spring
 - Medium, Preinstalled
 - Soft, Extra

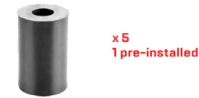
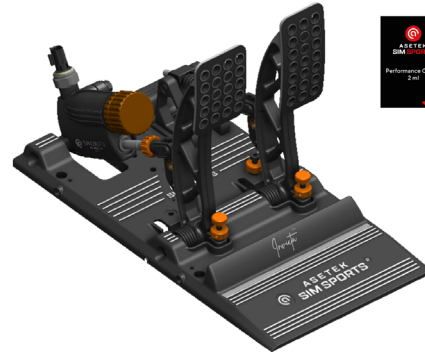
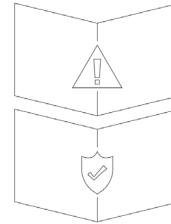
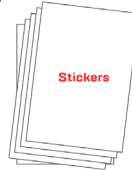

1.2 Videos

On the Asetek SimSports® YouTube channel (<https://www.youtube.com/aseteksimsports>), you will be able to find tutorial videos which, in detail, demonstrates numerous ways the pedals can be set up and used. You will also find additional information about the development and ambition for the Invicta™ pedals.

1.3 Manual version

This manual is version 1.0.
You will always be able to find the latest version of the manual at <https://www.asetek.com/simsports/knowledge-base/>

1.4 Support & Contact

Should you stumble upon further questions that are not covered in this manual or any of our detailed instruction videos, we encourage you to contact our friendly support staff via: <https://www.asetek.com/simsports/support/>

2. Product

2.1 Intended Use

Thank you for purchasing the Asetek SimSports® Invicta™ Pedals T.H.O.R.P.™ II; you have made an excellent choice! Asetek SimSports® pedals will bring you to the next level of your Sim Racing career. Whether you are a beginning or experienced gamer, you will feel the immersion of being in a real race car while racing the tracks across the globe in the virtual space.

The pedals are designed to be used in competitive sim racing and simulate the feel of a real race car. The pedals can be directly connected to any PC with a USB port and are intended to be mounted in a sim racing cockpit. The Brake & Throttle can be expanded/combined with the Asetek SimSports® Invicta™ Clutch pedal. The clutch pedal can be bought in our webshop or at an Asetek SimSports® authorized dealer.



The pedals are intended for indoor use only



Recommended ages 15 and above



2.2 Compatibility

Platform(s)	PC (Windows 10, 11)
Games	Assetto Corsa/Competizione/EVO GRID (2019)/2/Autosport/Legend Automobilista/2 Forza Motorsport/7 E.A. Sport WRC DiRT Rally/2.0 F1 Series iRacing Project CARS/2/3 rFactor/2/Demo/(Steam) + many other games that accept direct input devices

2.3 Reasonably Foreseeable Unintended Use

The following is considered misuse and may void the warranty:

- Use of adaptors or extension sets for cables;
- Use of other cables than provided with the product;
- Use in an environment that varies from or exceeds the given environmental conditions;
- Use that varies from or exceeds the given operating conditions;
- Failure to comply with the instructions in this manual;
- Failure to eliminate faults, malfunctions, or defects of the product that impose safety risks;

- Unauthorized removal or modification of parts or safety devices of the product;
- Use of spare parts or accessories that Asetek SimSports® has not approved;
- Mounting and/or use of any parts in a vehicle;
- Adjusting pedal settings during operation;
- Operation in a flammable and/or explosive environment.
- Dropping the throttle (quickly and completely removing your foot) from the point of actuation. This would not be a use in a real car, and the pedals are not designed to withstand these forces.

2.4 General Specifications

Dimensions (D x W x H)	418 x 212 x 256 mm
Weight	6 kg
Materials	Pedals: Aluminum PCB Housing: Plastic
Brake Cylinder Fluid	Hydraulic Oil
Sensor Types	Throttle: Hall sensor Brake: Liquid Pressure Sensor
Power Input	5V 500mA – Max. 2,5W
Operating Temperatures	15°C to 35°C, room temperature

3. Product Overview

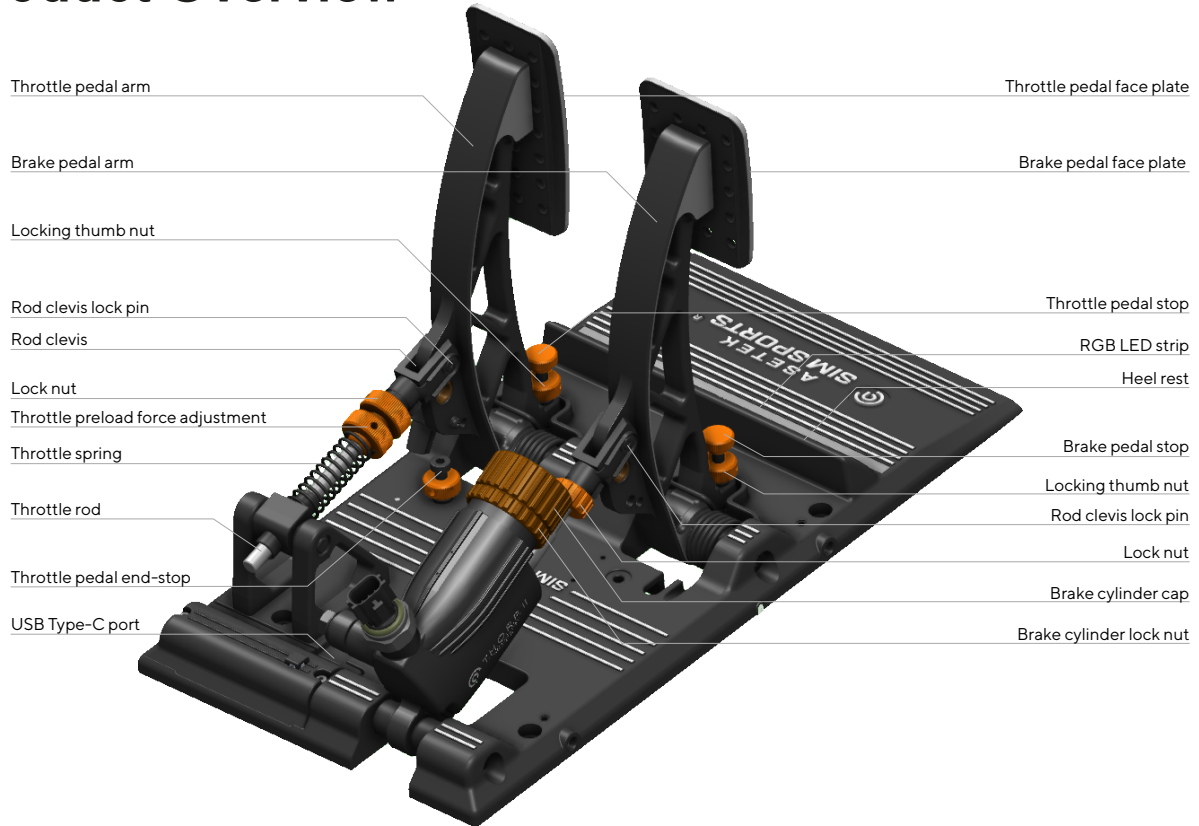

4. Getting Started

This section will teach you how to get your pedals set up and running. Later in the manual, you will learn much more about fine-tuning and software.

4.1 Installing your Pedals

4.1.1 Tools Required

To mount the pedals in your cockpit, you will need the following tools:

- Allen key, 3 mm (included)
- Allen key, 5 mm (included)
- Key wrench (not included)

4.1.2 Optional Tools

Depending on your rig and mounting preference, you may also need the following tools:

- Pencil or marker
- Screwdriver
- Power drill

4.1.3 Mounting to your Rig

The pedals are intended to be solely used while mounted to a sim racing rig.

The pedals have four (4) mounting holes in fixed positions. As such, all adjustments to the positioning of the base must be handled by your rig.

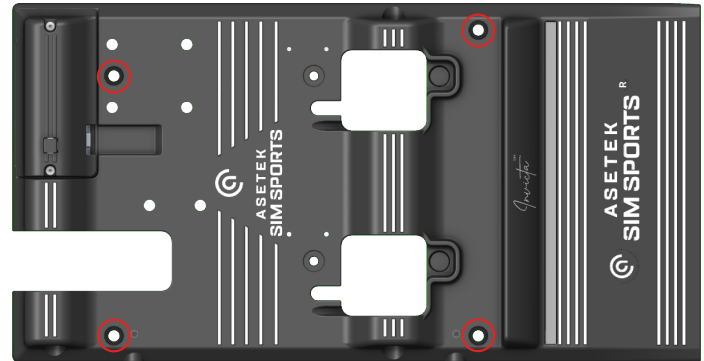

The baseplate is designed to be used with M6 screws, and holes in your rig should be with $\varnothing 6,4$ diameter. It is also compatible with the included M6 slot nuts.

The Asetek SimSports® Invicta™ T.H.O.R.P.™ II pedals are designed to withstand an extreme amount of braking force. Therefore, it is paramount that you install them on a very rigid base. Ideal conditions are in an aluminum profile cockpits, or a thick metal baseplate (as a minimum, we recommend: 3 mm, steel)

Mounting your pedals:

1. Carefully remove excess dust and debris from the installation location.
2. Place the pedals in their designated spot in your rig.
3. Align the holes in the pedals to four existing mounting holes in your sim rig, if available. Please note that the throttle assembly can be removed to access the mounting hole underneath easily.

CAUTION

Do not use the pedals without mounting them.

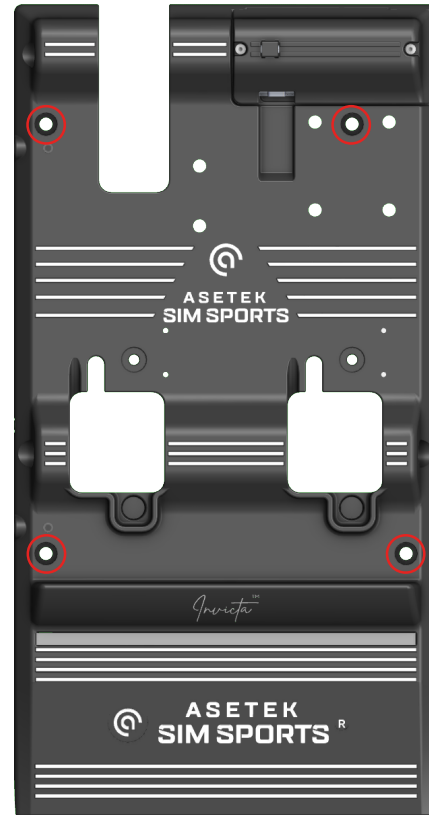

- a. Remove the rod clevis lock pin.
- b. Lift the rod.
- c. Remove the rod from the pivot bracket.

You can now access the mounting hole easily.

4. Mount the pedals to the existing holes using the four (4) provided M6x20 screws, four (4) washers, and four (4) nuts or four (4) M6 slot nuts (depending on your rig).

If there are no holes available or they do not line up, you can use the mounting hole schematics available here: <https://www.asetek.com/simsports/product/invicta-pedals-thorp-2/> or continue to step 5:

5. Mark the drilling locations.
6. Remove the pedals and drill four (4) Ø6.4 mm holes.
7. Mount the pedals to the holes using the four (4) provided M6x20 screws, four (4) washers, and four (4) bolts or M6 slot nuts (depending on your rig).

Congratulations. You have successfully mounted your Asetek SimSports® Invicta™ Pedals T.H.O.R.P.™ II to your rig. Enjoy the ride!

CAUTION

Please be aware that edges on the rod clevis can be sharp

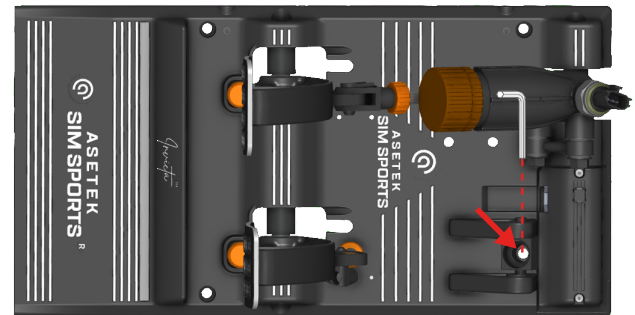
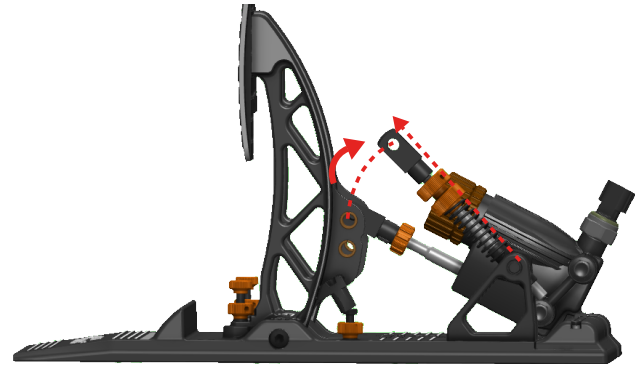

4.2 Adjusting the Pedals

CAUTION

Avoid eye contact with the lubrication grease and wash hands thoroughly after adjustment.

It is essential to make sure you have the correct pedal angle in any racing style. Setting this correctly will ensure maximum braking efficiency, allow you to use muscle memory to your advantage, and make you go even faster around the track!

The pedals are set up in their default configuration (out of the box) to give you maximum immersion. In other words, they are set up to be focused on realism – like what you would find in a real race car. The brake is at 90° to the base, and the throttle tilted a few degrees forward. This allows for the most efficient braking and will allow you to train your muscle memory to perfection while also maximizing your trail braking potential. The throttle and clutch pedals are further forward to ensure that you will hit the brake pedal as the first thing in an emergency on track.

The above setup is how it works in a real race car. We recommend you drive for several hours first and try to adapt. In a real race car, where you often have different drivers in the car (as well as in many endurance sim races), the pedals are adjusted like the

above, and there is no opportunity to change that specifically to any driver. It is just physics that you will have the most efficient braking when the brake pedal is at a 90-degree angle.

4.2.1 Pedal Face Plate Adjustments

NOTICE

Do not use a power drill, as this may damage the screws.

Invicta™ pedal face plates can be adjusted along the X and Y-axis. It will allow the pedals to accommodate a variety of different shoe sizes and increase performance and comfort for anyone using the pedals.

To adjust the position, follow these easy steps:

1. Remove the screws with an allen key from the pedal face plates
2. Align the pedal arms' holes with the pedal face plates' desired holes.



NOTICE

Only use the holes marked green for mounting.

3. Insert and fasten the screws with an allen key.

Note: The screws can bite hard, so be careful not to overtighten or have the tool slip. Recommended torque: 2nm

4.2.2 How Does the T.H.O.R.P.™ II System Function

You have chosen to buy an updated version of the most realistic brake system ever made for sim racing. In any given race car, the brake pedal is always hard. A hard brake pedal is faster (you can brake later) and it is required to properly trail brake and use your muscle memory to do so, as explained later. You can consider a race car braking system as 2 stages:

THE SOFT STAGE

Real race car:

When you apply pressure on the pedal, it will move 10–20 mm (measured on the pedal plate), while you build up pressure, while the caliper pistons are traveling to and pushing the brake pads against the brake disc, and to compensate for the small amount of play in all the mechanical parts on the pedal system that is required for them not to seize up.

T.H.O.R.P. System:

Since we do not have a brake disc, caliper and brake pads in a simulator, we made the slave cylinder to mimic this. The slave cylinder is compressing an elastomer, and like in a real race car, it will allow a pedal travel of maximum 42 mm measured on the pedal plate.

When full pedal travel is obtained, the slave cylinder will hit a mechanical stop, just like in a real race as described above. We supply different elastomers to mimic different feelings of the “soft stage”, but the different elastomers will not change the pedal travel, only how much force that is needed to fully depress the pedal and engage the hard stage.

THE HARD STAGE

Real race car:

When hydraulic pressure is built up, the brake pads are squeezing the discs hard and all mechanical play is compensated. In this stage, your foot is basically pressing against a wall, because now your muscles are pressing directly against the hydraulic forces (the brake fluid). Since the fluid cannot be compressed, you will feel the pedal is hard.

When a racecar driver complains about a “long” or a “soft” pedal, it is typically because there is air in the system, and since air CAN be compressed, the pedal will feel soft and long.

The mechanics then bleed the brakes for air, meaning there is only fluid left in the system, and the pedal is once again hard after passing the “soft stage”.

T.H.O.R.P. System:

When the slave system is mechanically locked, you have 100% the same feeling as in a racecar, when the brake pads are fully pressed against the brake disc, and your muscles are pressing directly against the hydraulic forces.

This is NOT simulated, this is the same and identical feeling as in a racecar, and you can keep pressing the pedal up to a hydraulic pressure of 100 bar, which corresponds to 185 kg of pressure on the pedal plate – the same as a real F1 car!

Besides being able to calibrate and measure the pressure in bars, the 2-stage system is exactly the benefit you will get over a mechanical brake system. Most mechanical brakes are relying on the elastomers and a load cell to give you the race car feeling. It will never be the same, because it is NOT the same! A load cell system IS a simulation and at best, you can implement a mechanical stop to simulate the “hard stage”, but unlike the T.H.O.R.P.™ system, your pressure readings in the simulator will also stop at that point, because your load cell will stop to physical deflect. And without deflection it will not measure. In the T.H.O.R.P.™ system, pressure readings will continue to rise despite the slave cylinder having reached its mechanical stop (passed the “soft stage”).

That is the Asetek SimSports® Invicta™ T.H.O.R.P.™ II hydraulic difference!

Your control over the car relies on precise pedal inputs.

Mastering these inputs demands a brake pedal that maintains consistency over time, ensuring that your muscle memory engages with the same pedal hardness every time you get into the driver’s seat.

And this is exactly why our pedal brakes are intentionally hard with a short travel distance as default. This approach enhances the use of muscle memory which is fundamental for delivering consistent performances and get around the track faster than ever.

THE BENEFITS OF A HARD BRAKE PEDAL

Having a hard brake pedal will allow your muscle memory to be trained to perfection. Muscle memory is the subconscious telling your muscles just the right amount of pressure, leaving your conscious mind to take care of more important things at that moment – like watching traffic or hitting apex.

Your muscle memory system is not wired to remember a position. Try to lift your hand with your eyes closed and reach the same spot within 0,5 mm 10 times in a row, and you will get the point.

On the flip side, your muscle memory can memorize a pressure extremely accurately, meaning going around a track, your muscle memory can make you brake the same way again and again. This cannot be achieved with a soft pedal – especially when trail braking.

**BRAKE LATER.
GET FASTER.**

Furthermore, a hard brake pedal will allow you to brake later. Imagine having a brake pedal with 50 mm (common for many sim racers) of travel versus a brake pedal with almost zero travel.

You are going 300 km/h down a straight. With the long travel brake, it will physically take you perhaps 1/10 of a second more to reach full braking power. On the stiff brake pedal, you will reach maximum braking power instantly. If you have three hard braking zones on a track, you will gain 3/10 of a second each lap by using a hard brake with minimal travel.

 **NOTICE**

Should you wish to change the pedal stops, and thereby the angle of the pedals, it can be done entirely toolless. It will require you to recalibrate the pedals and remove the brake cylinder at the pedal arm and adjust the rod length to prevent any preload on the T.H.O.R.P.™ II hydraulic master brake cylinder. Having a preload on the master cylinder will result in an inconsistent and a fluctuating calibration!

4.2.3 Adjusting the Brake Pedal Angle

1. To adjust the brake pedal angle, you will have to remove the clevis attaching the T.H.O.R.P.™ II. brake cylinder. To achieve this, you must first unlock the thumbnut on the rod.

CAUTION

Please be aware that edges on the rod clevis can be sharp

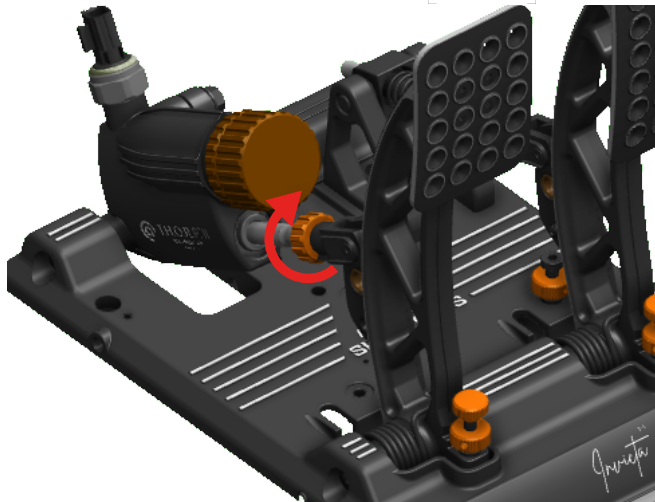

2. Remove the clevis lock pin

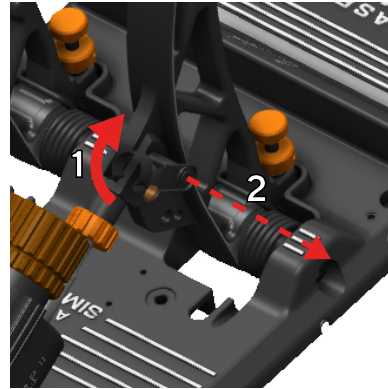

3. Swing the cylinder out of the way

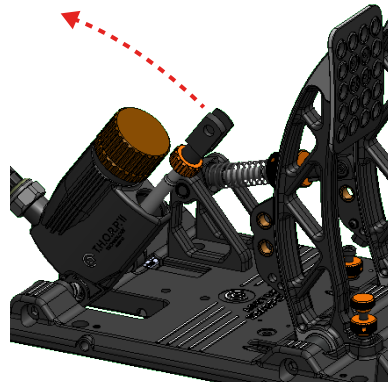

4. When the cylinder is out of the way, you can adjust the pedal stops by loosening the locking thumbnut

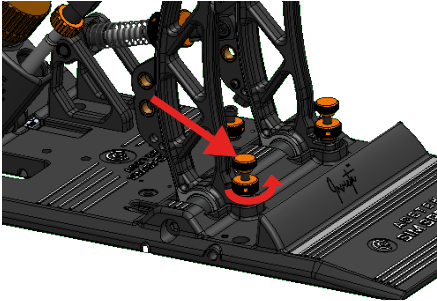

5. Push the pedal slightly forward, and rotate the thumbscrew

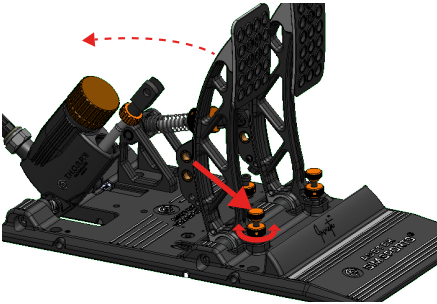

6. Once you have achieved your desired position, tighten the locking thumbnut

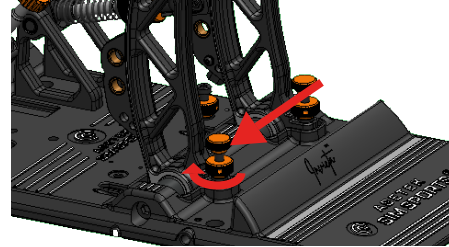

7. Adjust the pushrod length by turning the clevis until it perfectly matches up with the hole in the pedal arm. Re-insert the clevis lock pin.

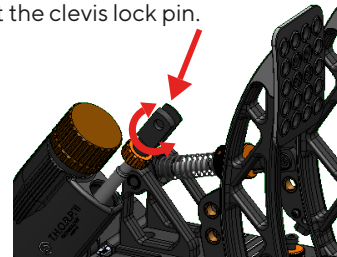

This way, there is no preload on the brake cylinder, which is essential to achieve a 100% stable calibration and not prematurely wear out the brake cylinder. Once these steps are completed, you should recalibrate.

4.2.4 Throttle Pedal Angle Adjustment

1. You can adjust the pedal stops on the throttle pedal by loosening the locking thumbnut



2. Remove the rod clevis and lift up the rod.

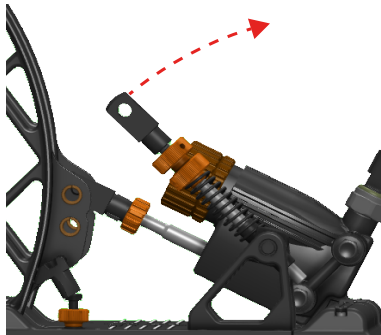

3. Push the pedal slightly forward, and rotate the thumbscrew (Clockwise to move the pedal forwards, Counter-Clockwise to move the pedal backwards)

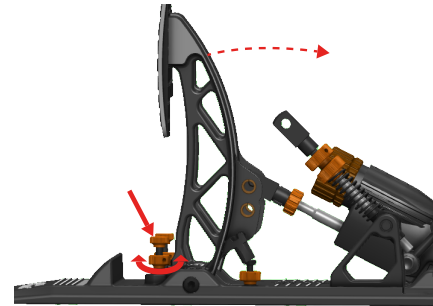

4. Once you have achieved your desired position, tighten the locking thumbnut

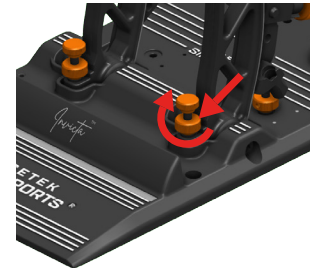

5. Recalibrate your pedals in RaceHub™ (see section 5.3 Pedal Calibration)

4.2.5 Throttle Preload Adjustment

NOTICE

Always remember that the spring must not act as a stop, instead adjust the throttle pedal stop (see 4.2.7 throttle travel distance adjustment)

For the Invicta™ throttle, you have the option of replacing the spring for a softer feeling (4.2.6 Throttle Spring Replacement). But you can also adjust the preload on both springs.

Adjusting the preload on the throttle spring will shorten the overall spring length, increasing the amount of force needed to activate the throttle initially. Doing so will keep the throttle curves the same but change the initial power required to activate it.

Adjusting the throttle preload can be done in three (3) simple steps:

1. Turning clockwise, loosen the uppermost thumbnut, which locks the lowermost thumbnut in place. It is the one closest to the pedal itself.



2. Adjust preload on the spring by turning the bottom thumbnut (in contact with the spring):
 - a. Counterclockwise to tighten the preload, making the throttle require more force to engage.
 - b. Clockwise to reduce the preload, making the throttle require less force to engage.

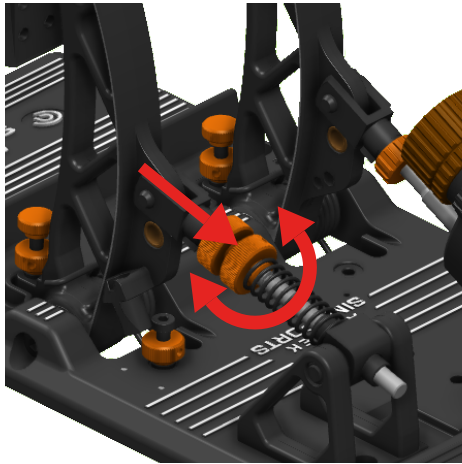

3. Turn the uppermost thumbnut counterclockwise to re-tighten it, locking the bottom thumbnut in its position.

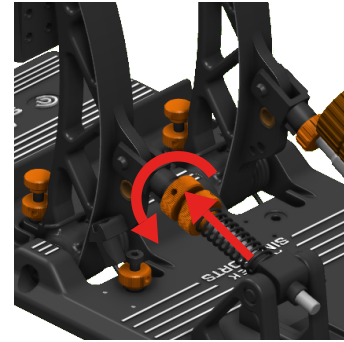

4. Recalibrate your pedals in RaceHub™.

NOTICE

Remember to adjust the pedal stop, to make sure the pedal arm rests on the pedal stop and not the spring, when fully activated.

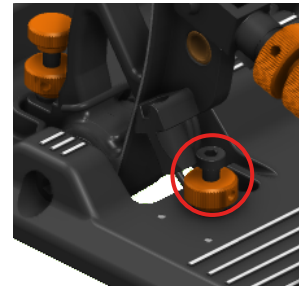

4.2.6 Throttle Spring Replacement

To give you a variety of different customization options, that allow you to bridge the gap between sim racing and real world racing with precision, we include two (2) springs with the Invicta™ pedals. One, the stiffer option, is preinstalled in the throttle. The other, is in the supplied box of accessories.

Replacing the throttle spring is a quick and easy process. Simply follow these seven (7) steps:

1. Remove the rod clevis lock pin.

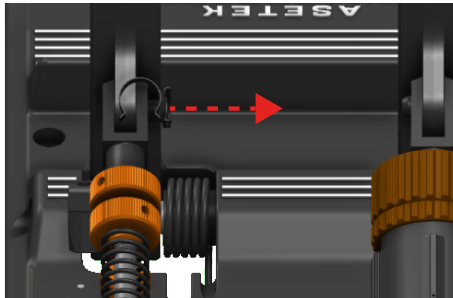

CAUTION

Please be aware that edges on the rod clevis can be sharp



2. Lift the rod free of the pedal arm.

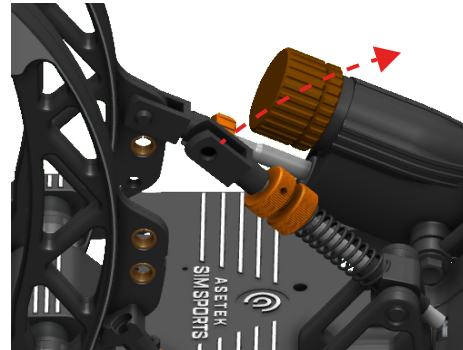

3. Remove the rod with spring from the pivot bracket.

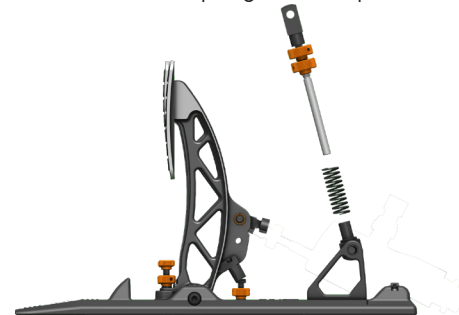

- a. At this point you can also access the installation point beneath, easily

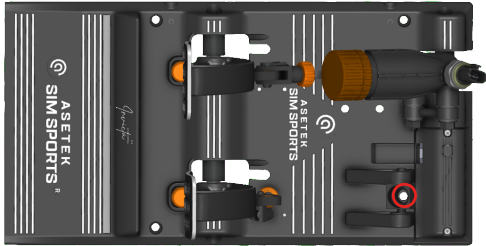

- 4. Remove the spring from the rod
- 5. Install your new spring on the rod
- 6. Reinsert the rod with spring, into the pivot bracket

- 7. Reinsert the rod clevis lock pin, and make sure it is locked firmly into place

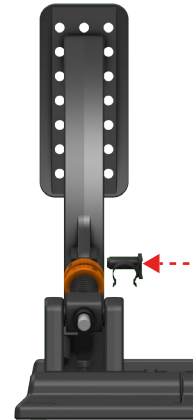

 **CAUTION**

Make sure the mounting of the pedal is set and all parts are secured tightly before use

4.2.7 Throttle Travel Distance Adjustment

The throttle can have its travel distance adjusted. This allows you to set a new pedal stop of your throttle pedal – essentially reducing the distance of activation and the feeling of resistance as you move through less of the available spring distance.

The process can be done in three (3) simple steps:

1. Loosen the thumbnut on the pedal stop, behind the pedal arm, by rotating it counterclockwise



2. Use an allen key to adjust the height of the allen screw.

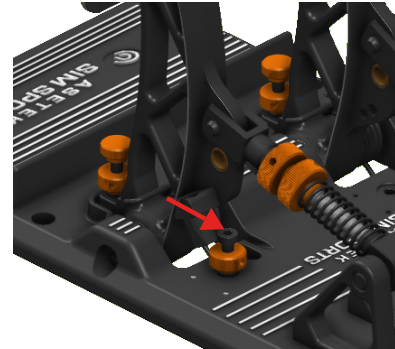

3. Re-tighten the thumbnut by rotating it clockwise.

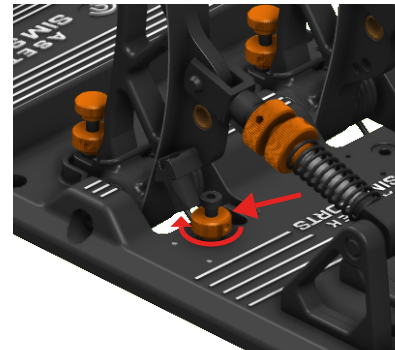

4.2.8 Adjust the Brake Pedal Attack Point

Adjusting the brake pedal attack point allows you to customize the angle of travel on the brake pedal.

1. To adjust the brake pedal attack point, you will have to remove the clevis attaching the T.H.O.R.P.™ II. brake cylinder. To achieve this you must first loosen the thumbnut on the rod.

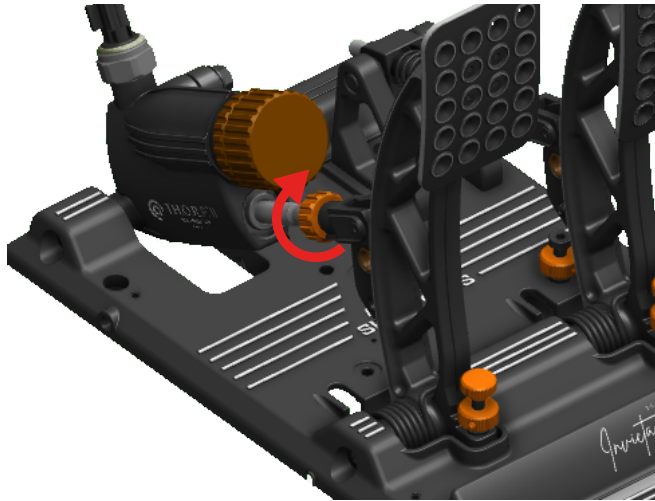

2. Remove the clevis lock pin. Push the Rod clevis lock pin upward to detach the pedal arm from the rod clevis and pull the pin outwards.

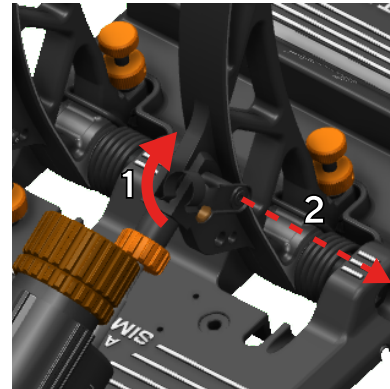

3. Identify the brake rod mounting holes on the brake pedal
 - a. Align the brake pedal rod with the lower hole of the brake pedal arm to change the attack point of the pedal, essentially reducing the amount of force needed to brake = softer brake pedal.
 - b. Align the brake pedal rod with the upper hole to increase the amount of force needed to brake = harder brake pedal.

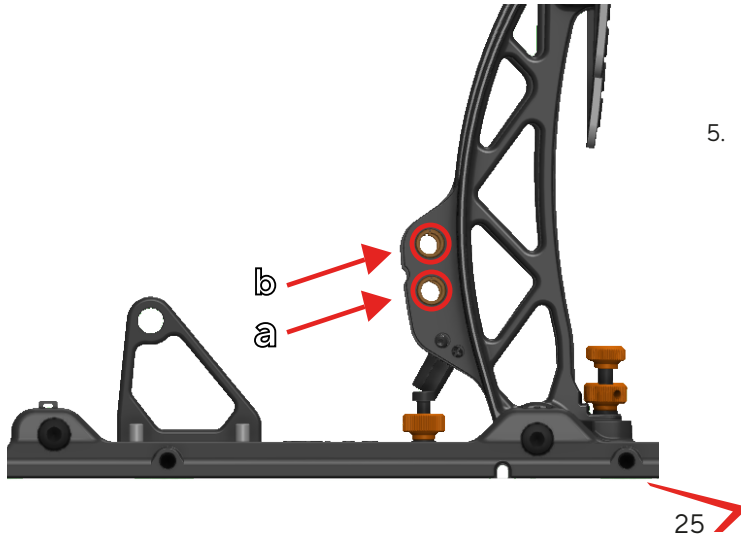

4. Adjust the pushrod length by turning the clevis until it perfectly matches up with the chosen hole in the pedal arm. Re-insert the clevis lock pin.

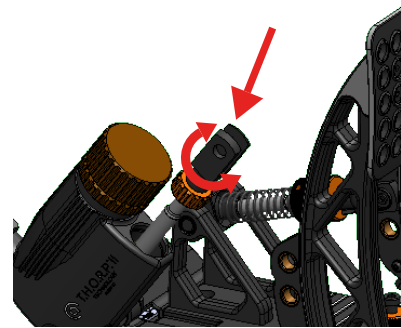

5. Recalibrate the pedals in RaceHub™

4.2.9 Swapping Elastomers

Swapping the included elastomers will allow you to customize the resistance on your brake pedal.

Be aware that by adjusting which elastomer you use, you effectively change the amount of travel you get with a certain amount of applied force. For example, applying 50 kg of force to the pedal may give you 12mm of travel with the white elastomer, but only 6mm with the green elastomer (note: not actual numbers).

You can adjust the pressure (bar) you want to be 100% brake force in RaceHub™.

Changing the elastomers is quick. Just follow these few simple steps:

1. Loosen the orange lock nut on the most outer part of the brake cylinder by turning it clockwise .

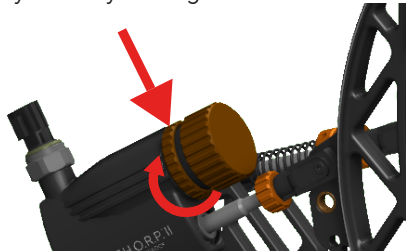

2. Turn the brake cylinder cap counter-clockwise until it comes out of the shaft.

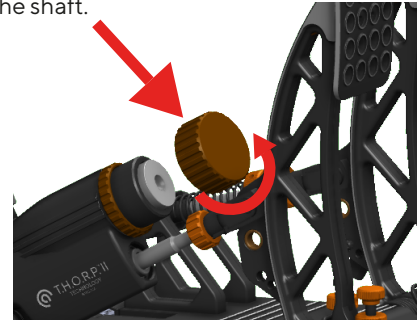

3. Press on the brake pedal with your hand until the elastomer with elastomer guide is visible. You can now take the elastomer with the elastomer guide out with ease.

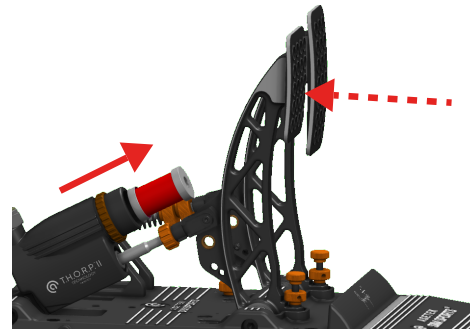

Take of the elastomer guide from both the top and bottom of the elastomer

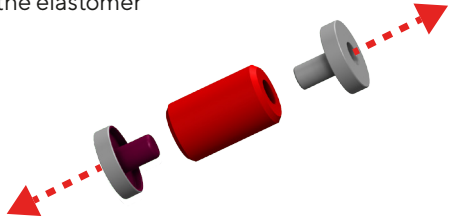

4. Choose your preferred elastomer
— see section 4.2.10 for hardness

5. Attach the elastomer guide on the new elastomer

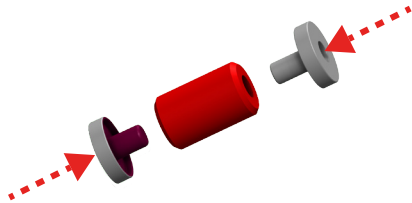

6. Place the elastomer with elastomer guides attached all inside of the brake cylinder

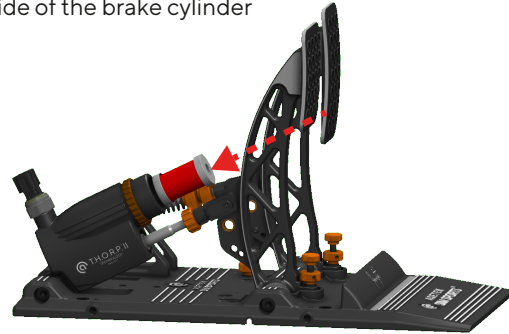

7. Grab the cylinder cap and screw it onto the brake cylinder clockwise, until you can feel light resistance from the top of the elastomer.

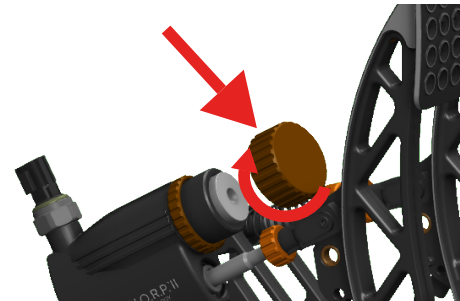

8. Tighten the orange lock nut on the most outer part of the brake cylinder by rotating it counter-clockwise to brake cylinder cap.

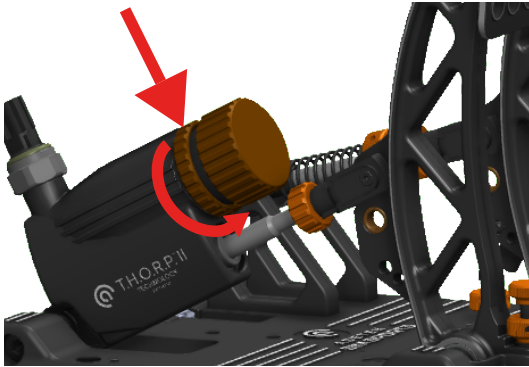

9. Recalibrate the pedals in RaceHub™

4.2.10 Elastomer Types

We include five (5) different elastomers from the factory that provides different sensations.

Elastomer Comparison Chart:

Colors	Firmness
Red	Extra Hard
Orange	Hard
Yellow	Medium
Green	Soft
Light Green	Extra Soft

These are our recommendations if you want to adapt your pedal to something that will feel close to the real deal:

- Formula, LMP, and similar cars: Extra Hard or Hard
- Rally, Nascar, and GT: Hard or Medium
- Road cars: Soft or Extra Soft

Note: Please be aware that only the included elastomer lengths, hardness's and types, or those sold on the Asetek SimSports® Webshop, are officially supported by Asetek SimSports®. Failure as a result of using different elastomer hardness's, types, or lengths will void your warranty.

CAUTION

Make sure the mounting of the pedal is set and all parts are secured tightly before use.

4.2.11 Brake Pedal Preload Adjustment

To simulate the caliper/pad to disc gap that exists in any real car – we have implemented a solution that easily lets you adjust just how much gap you want to use. To change the brake pedal preload, follow these steps:

1. Turning clockwise, loosen the thumbnut, which locks the brake pedal arm in place.

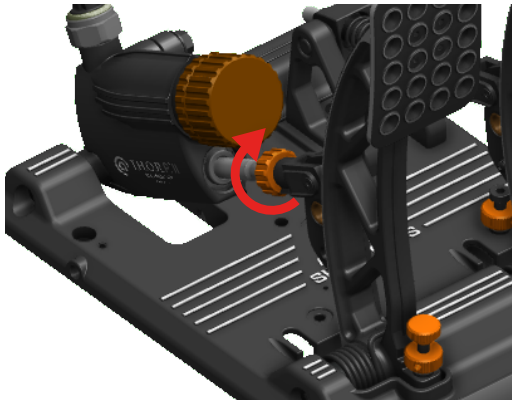

2. Push the Rod clevis lock pin upward to detach the pedal arm from the rod clevis and pull the pin outwards.

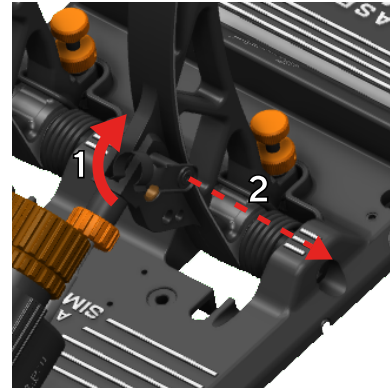

3. Swing the pedal rod out of the way.

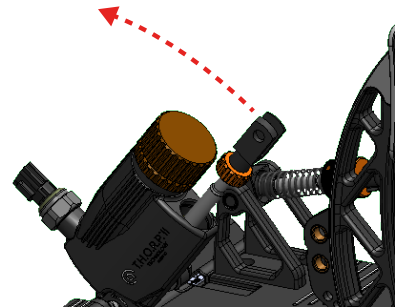

4. Push the brake pedal arm slightly forwards by pressing on it with your hand and loosen the locking thumbnut.

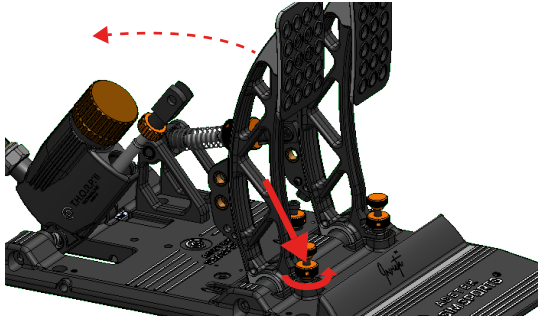

5. While compressed, adjust the position of the pedal arm by turning the thumb screw. Counter-clockwise will increase and clockwise will decrease the distance between the pedal arm and the brake rod.

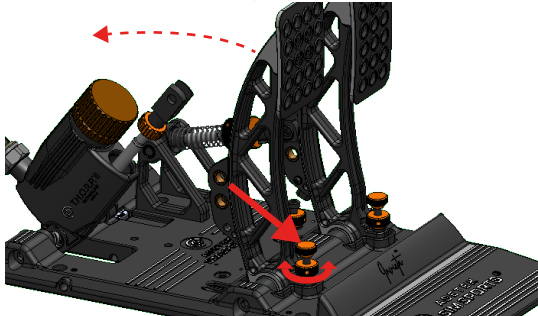

6. Tighten the locking thumbnut on the brake adjustment screw clockwise to secure it.

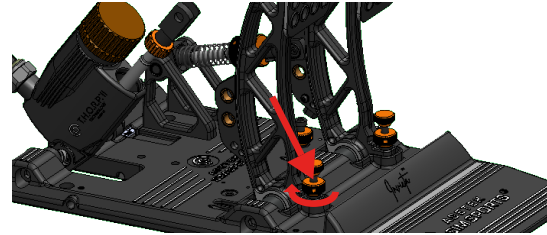

7. Turning the clevis rod counter-clockwise will decrease the length of the brake rod, giving you some 'play' before you actively engage the brake.

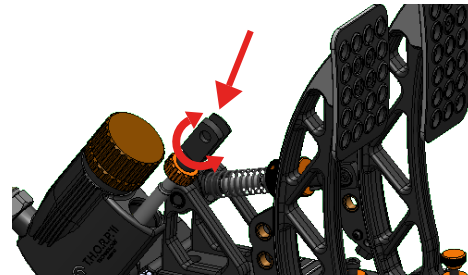

8. Push the pedal arm forwards aligning it with the pin hole of the rod clevis, and push the rod clevis lock back in its place.

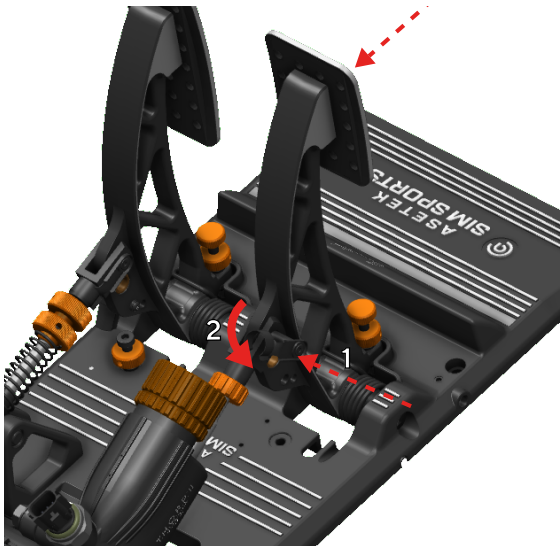

9. Recalibrate your pedals in RaceHub™.

⚠ CAUTION

Make sure the mounting of the pedal is set and all parts are secured tightly before use

4.3 Connecting to your PC

In our relentless quest to make your experience as seamless and immersive as possible, we have gone to great lengths to simplify this process, too.

You will find a little dark-tinted plastic cover behind the throttle on your Invicta™ pedals. This houses the PCB for your entire pedal set (and your clutch, too, should you decide to add one). We have opted for a single USB Type-C interface to make things simple to connect and maintain.

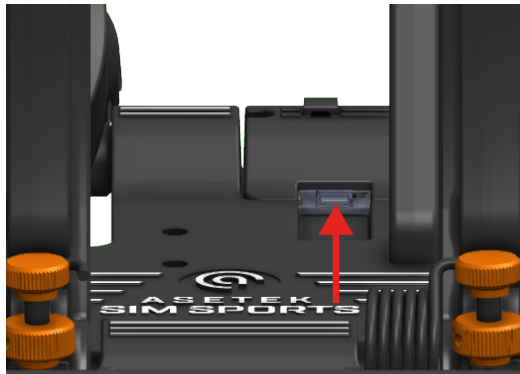

When installing your pedals, you will find that the USB Type-C female connector is pointing towards the throttle, not towards the pedal set's rear. This was a very intentional choice on our side to make sure you will not accidentally break the connector. Note also the small cable clip on the top of the cover. We want to make sure that your cable is not strained and suggest you use the provided clip to alleviate any potential strain on the cable.



Connecting is now a simple task.

If you connect directly to your PC, we recommend using the USB Type-C to USB Type-A cable.

Plug the Type-C end into your pedals and the Type-A end into your PC. Your PC will recognize the Asetek SimSports® Invicta™ Pedals T.H.O.R.P.™ II. Proceed to install RaceHub™ and configure your pedals to your liking (See section 5 for instructions).

If you connect to an Asetek SimSports® Direct-Drive wheelbase, we suggest using the USB Type-C to USB Type-C cable, to connect your pedals directly to your wheelbase.

Plug one end into your pedals and the other into your wheelbase. Open RaceHub™ and configure your pedals to your liking (See section 5 for instructions).

4.4 Start Racing!

Your pedals are ready for racing – even without adjusting them in the software. From our factory, they are calibrated with a maximum pressure of 40 bar. The stock elastomer can be switched as you desire – our recommended is the standard hard elastomer (see section 4.2.10 for hardness).

Again – before changing anything, try to drive for several hours and adapt to the feeling of a real race car.

Assign the pedals in your favorite simulator game, and you are ready to go.

5. RaceHub™ Adjustments

All Asetek SimSports® products come with an extremely powerful yet easy-to-use piece of software that we have developed from the ground up. It is called RaceHub™ and will take care of your every need. RaceHub™ unlocks things you would not dare to dream and is continuously updated.

5.1 RaceHub™ Download

RaceHub™ is available for download, in its newest version, on our website (www.asetek.com/simsports/racehub).

5.1.1 RaceHub™ Installation

After completing the download from our website, double-click the downloaded file to initiate the installation. Follow the on-screen instructions and install them in your desired directory. Once installed, open RaceHub™ using the shortcut on your desktop or in your programs folder.

5.1.2 RaceHub™ Updating

RaceHub™ will automatically notify you if there are available updates for the software. If you want to double-check, please go to www.asetek.com/simsports/racehub and download the newest version.

RaceHub™ has a built-in feature that allows you to update the firmware on your devices automatically.

5.2 Introduction

Asetek SimSports® RaceHub™ allows you to make a plethora of adjustments to your Asetek SimSports Invicta™ Pedals T.H.O.R.P.™ II, it will allow you to adjust pedal maps, calibrate your pedals, adjust the aRGB lighting, and much more.

Everything is available in a highly user-friendly interface that allows for quick and easy customization that not only gives you complete control but does it in a manner where you are constantly in focus – teaching you everything you need to know to become a power user and expert sim racer.

The settings that you choose in RaceHub™ will be applied to all the supported games found in section 2.2, “Compatibility”—ensuring maximum performance and precision!

5.3 Pedal Calibration

To ensure your pedals are as precise as they can be, you should run the pedal calibration wizard in RaceHub™. It is a quick and straightforward process that takes you through a series of activations that calibrate your pedals.

1. Navigate to the pane in RaceHub™ called Calibration
2. Push the calibrate button

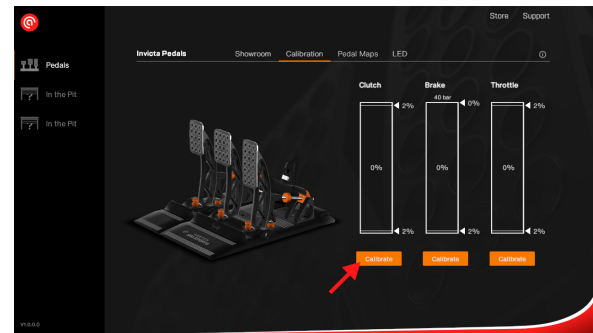

3. Follow the on screen instructions
4. Done! Your calibration will carry over into all the supported games.

Once your pedals are calibrated, only a few unique scenarios will cause a need for recalibration:

- a. If so desired, you have adjusted both mechanical pedal stops of your throttle and clutch pedals
- b. If so desired, you have adjusted the mechanical pedal stop of the brake pedal

5.4 Deadzone Adjustments

In RaceHub™, you will be able to set both top and bottom deadzones on all your pedals.

A bottom deadzone allows you to slightly activate your pedal without engaging the brake. For example if you rest your foot on the pedal.

A top deadzone allows you to modify the point of full activation. In the case of a throttle pedal, this would allow you to reach 100% throttle before your throttle pedal reaches full activation and the mechanical pedal stop. This preference is individual and generally done by a race engineer before the car goes on track. RaceHub™ allows you to customize it fully, and we strongly encourage you to do it as well, to not lose potential speed and lap time.

The top and bottom deadzones can be adjusted using this slider marked here:

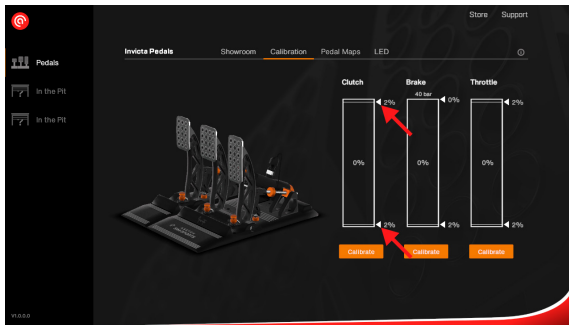

We suggest the following settings for deadzone when using the Asetek SimSports® Invicta™ pedals, which is how it is calibrated from our factory.

Throttle:

- Top: 2%
- Bottom: 2%

Brake:

- Top: 0%
- Bottom: 2%

5.5 Maximum Brake Force Adjustment

RaceHub™ allows you to calibrate your brake with accurate hydraulic measurements like in a real race car, giving you the ultimate immersion and precision you would get in a real car. The calibration of your Invicta™ pedals is measured in a numerical value of bar pressure.

The maximum pressure supported is 100 bar, which directly corresponds to 185 kilos of pressure.

However should you require less pressure to reach what the simulator is recognizing to be 100% brake application, you can calibrate whichever pressure you want to equal 100%.

5.6 Custom Pedal Mapping

One of the great features of RaceHub™ is the ability to map the curves of your pedals precisely to your liking. In most racing simulator pedals, you will find a 1:1 relation between the amount pressed on the pedal and the response in-game. This is not how things work in real racing – so why should it be this way in your sim rig? The answer is, it should not, and our pedal maps help you avoid just that.

We have made a few preset curves that mimic typical scenarios, but the RaceHub™ software also allows complete customization of your pedal curves. Click, drag and drop – it is that simple!



As we briefly mentioned, a real race car will not have a linear throttle response. An example will be an Audi R8 LMS GT3, which has less activation of the throttle at the beginning of the pedal activation, increasing as you progress through the travel. Similarly, you can adjust your curves based on your driving conditions—all in search of ultimate performance.



Please note that RaceHub™ custom pedal maps work best when they are used exclusively and without the use of potential in-game settings. If your preferred simulator game offers a pedal mapping feature, we highly suggest you leave it as linear and instead use the functionality in RaceHub™.

6. Compatible Products

Asetek SimSports® offers compatible products to increase your experience driving with the Invicta™ Pedals T.H.O.R.P.™ II even further. These can be purchased at the Asetek SimSports® webshop or at Asetek SimSports® authorized dealer.

6.1. Asetek SimSports® Invicta™ Clutch

For racers who enters Rally or Thrift races, it essential with a proper clutch. Asetek SimSports® Invicta™ Clutch was designed and tested rigorously during development to ensure that the racer will feel a realistic bite point when shifting gears in the racing simulator. The fierce spring load gives you a realistic and slamming rebound, and a feeling of true engagement exactly like you will feel from the slave cylinder and clutch release bearing in a real race car.

The intuitive design allows for easy adjustment of force and a mechanical change of pedal curves. Mapping out the curve to your needs gives you the engagement that ensures the best clutch performance for your needs. The Invicta™ clutch will help you gain all-important milliseconds while shifting.

Information on the manual and guidance in how to attach the clutch to the Invicta™ Brake & Throttle can be found here:
<https://www.asetek.com/simsports/product/invicta-pedals-clutch/>

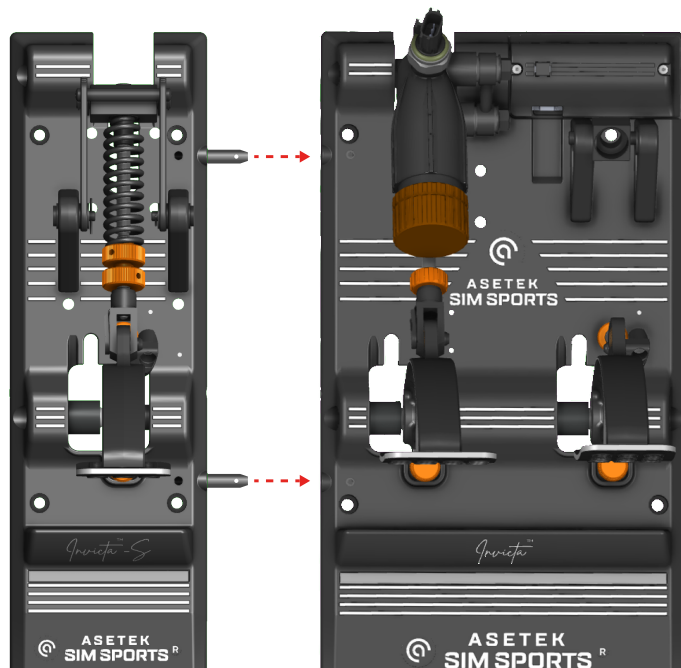

6.2. Universal Footrest

The all-aluminum footrest, for the throttle pedal, carries over design elements of Asetek SimSports®, allowing the driver to rest the foot during long races.

Imagine driving 24H endurance races, even in a static position it will naturally be exhausting for your body, and especially legs as you don't have the opportunity to put the car in cruise control. Awareness at the track is important at all times to make sure you hit the brake with exceptional timing and precision. Once you make the turn down the straightaway, you just need to hit the throttle and accelerate to gain as many seconds as possible before entering the next turn.

The driver can rest his foot against the footrest to relax his foot and knee while racing. Furthermore, in rigs with tight space, it will prevent the foot from rubbing against the rig/chassis.

The footrest is a quick-to-mount accessory that will improve your ergonomics while driving, and help you avoid unintended slips of pedals, when you are three hours in your endurance race.

Information on the manual and guidance in how to attach the footrest to the pedal set. Throttle can be found here: <https://www.youtube.com/watch?v=ZXzyHPTkrEc>



7. Maintenance

Owning a set of Invicta™ Pedals T.H.O.R.P.™ II pedals means a minimum of maintenance needed. However, we do have a few suggestions that will help you keep your pedals feeling supreme.

7.1 Throttle Maintenance

We suggest you clean the throttle with regular intervals (6 months) with a soft, dry, clean cloth.

If unwanted rubbing sounds occur, we suggest using PTFE Dry Spray.

NOTICE

Do not use water or cleaning agents to clean the product.

7.2 Brake Maintenance

We suggest you clean the brake with regular intervals (3 months or 100 hours of use) with a soft, dry, clean cloth.

Likewise, with regular intervals, we suggest lubricating the rods of the hydraulic cylinder with mineral oil.

NOTICE

Do not use water or cleaning agents to clean the product.

7.3 Spare Parts

We strongly advise you to only use original Asetek SimSports® spare parts. Failure to do so will void your warranty.

If you have questions, or do not know if you have an original part, please refer to www.aseteksimsports.com or consult the Asetek SimSports® support via: www.asetek.com/simsports/support

8. Troubleshooting

Sometimes unforeseen issues occur. But do not worry, we are here to help.

If you are having issues we suggest consulting the FAQ and Troubleshooting of Pedals on:

<https://www.asetek.com/simsports/knowledge-base/general-faq/>

<https://www.asetek.com/simsports/knowledge-base/troubleshooting/>

If you are not able to find a solution on the FAQ or Troubleshooting page, please consult our friendly and knowledgeable support staff via:

www.asetek.com/simsports/support

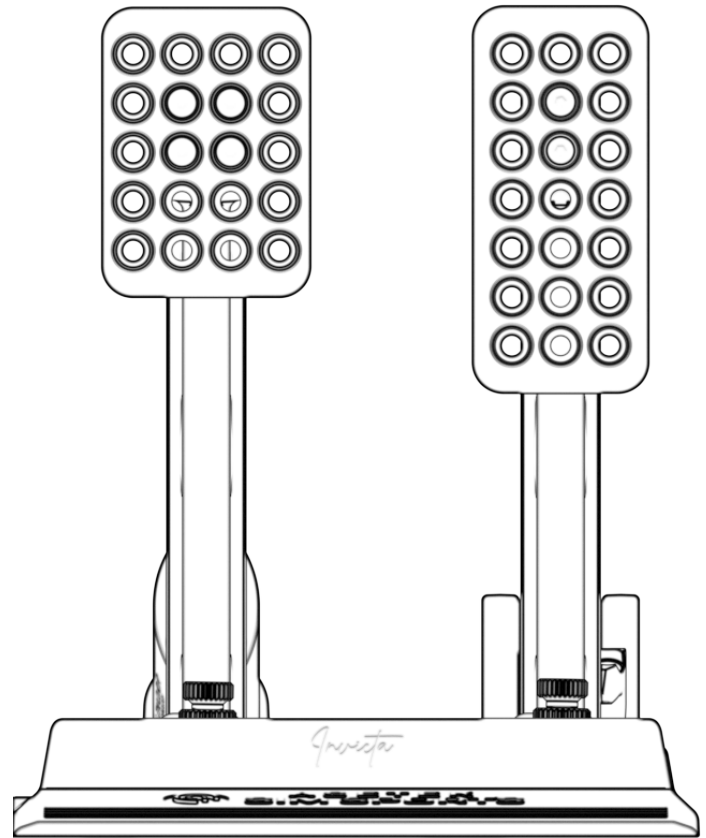

9. Safety

- The device must not be exposed to rain or humidity to avoid the risk of fire and electric shock.
- We strongly advise you not to drive a vehicle immediately after racing simulation games.
- This product is not intended for children under the age of 15 years.
- Contains small pieces. Danger of swallowing!
- Extended periods of gaming may cause health risks. Take a break of 5 minutes every 20 minutes, and do not play for more than 2 hours per day.
- Keep hands, fingers, hair, clothing, and jewelry away from the product when in use.
- Only one person may use the product at any given time. Keep other persons away from the product when in use.
- Keep the product and the power cord away from children and pets.
- This product contains components that the user cannot repair. Opening parts of the product may compromise the safe use of the product and will void the warranty.
- Do not disassemble this product beyond what is described in the product manual.
- Avoid eye contact with the lubrication grease and wash hands thoroughly after adjustment.
- Make sure the mounting of the pedal set and all parts are secured tightly before use.
- Check frequently that the pedals are mounted properly
- Be aware that the rod clevis has sharp edges
- In the unlikely event of hydraulic oil leakage, avoid contact with skin. In case of exposure, wash the contaminated area thoroughly with soap and water. Do not ingest. In case of ingestion, rinse mouth thoroughly and drink 1-2 glasses of water in small sips. Do not induce vomiting. If vomiting occurs, keep head low to prevent stomach contents from entering lungs.

10. De-commissioning & Sustainability

At Asetek we are fiercely committed to making the world a sustainable place. You can read more about Asetek's sustainability efforts, including our sustainability reports, here: www.asetek.com/company/sustainability

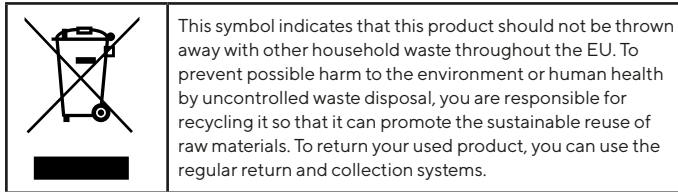

10.1 Packaging

All packaging is made out of paper and cardboard. All our cardboard and paper products are labeled with the FSC mark, ensuring maximum reusability and that the forests are sustainably forested. Furthermore, we regularly check our vendors to make sure they are upholding their commitments.

About FSC: www.fsc.org/en/fsc-labels

If you need to dispose of your packaging, please use the appropriate paper waste stream in your country, to dispose of the packaging. Naturally, we hope you want to keep it around – we are quite proud of it.

10.2 Product

Asetek SimSports® is committed to making products that will last. However, we also know that sometimes things break, and that should not result in a scrap and forget, producing even more e-waste to our planet. That is why we are dedicated to supporting you and all other users with spare parts where possible, and in case of parts of the product defuncting, we offer return shipping of the part along with a new service part. We will then make sure the original part is de-commissioned in an environmentally sound manner.

If you feel uncertain about how to recycle any Asetek SimSports® product, we suggest getting in touch with our dedicated customer support team, who will happily help you. Contact them here: www.asetek.com/simsports/support

10.3 Production

The Asetek SimSports® Invicta™ Pedals are produced using primarily aluminum die-casting and forging techniques. As such, any waste aluminum is re-used, minimizing waste.

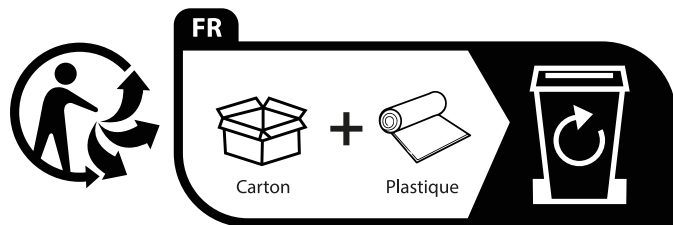

Points de collecte sur www.quefairedemesdechets.fr
Privilégiez la réparation ou le don de votre appareil !

11. Declaration of Conformity

We, Asetek, as manufacturer, declare that the Invicta™ products from the brand Asetek, are tested according to all relevant CE standards/regulations and passed all tests.

The complete Declaration of Conformity can be found and downloaded from:

<https://www.asetek.com/simsports/declarations/>



Invicta™