

INITIUM™
Pedal Set
Manual

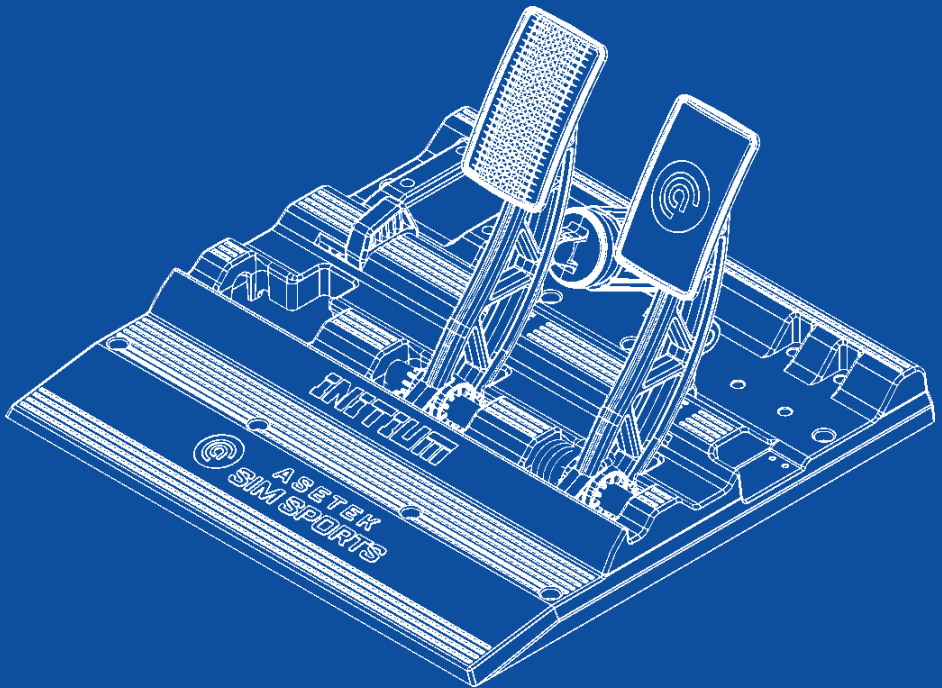

**Thank you for purchasing the
Asetek Racing™ Initium™ Pedal set.**

You have made an excellent choice! We are sure the
Initium™ Brake & Throttle Pedals will help you take your
sim racing experience to the next level.

Whether you are a seasoned racer or a gamer who wants
to dive into something new, the Initium Pedals are made to
fit every user.

Prepare for the sensation of being in a real race car.

Table of contents

Foreword	4
About This Document	4
Symbols Used	5
Copyright	5
1. Introduction	6
1.1 Box Contents	6
1.2 Videos	7
1.3 Manual version	7
1.4 Support & Contact	7
2. Product	8
2.1 Intended Use	8
2.2 Compatibility	8
2.3 Reasonably Foreseeable Unintended Use	9
2.4 General Specifications	9
3. Product Overview	10
4. Getting Started	11
4.1 Mounting Instructions	11
4.1.1 Mounting Options	11
4.1.2 Tools and Supplies Required for mounting to a cockpit	11
4.1.3 Optional Tools for mounting to a cockpit	11
4.1.4 Switching Modes	12
4.1.4.a Floor Mode	17
4.1.4.b Mounting to a Cockpit	17
4.2 Adjusting the brake pedal hardness	18
4.3 Connecting to your PC or Xbox Series X S	22
5. RaceHub™ Adjustments	23
5.1 RaceHub Download	23
5.1.1 RaceHub Installation	23
5.1.2 RaceHub Updating	23
5.2 Introduction	23
5.3 Pedal Calibration	24
5.4 Deadzone Adjustments	25
5.5 Maximum Brake Force Adjustment	26
5.6 Custom Pedal Mapping	26
6. Compatible products	27
7. Maintenance	27
7.1 Throttle Maintenance	27
7.2 Brake Maintenance	27
7.3 Spare Parts	27
8. Troubleshooting	28
9. Safety	29
10. De-commissioning & Sustainability	30
10.1 Packaging	30
10.2 Product	31
11. Declaration of conformity	31

Foreword

About This Document

This manual is written for the end-user of the Asetek Racing™ Initium™ Pedal Set (hereon after: “pedals”) and contains all information required to correctly and safely install, use and maintain the following model:

Model Name	BTC-3
Product Name	Initium™ Pedal Set
Product Code	40-010-0010010

This manual was authored in English. All other languages are translations of the original document.

Please make sure that you have thoroughly read and understood all contents of this manual before installing, using, or performing maintenance on the pedals. If anything in this manual is unclear, please contact Asetek SimSports Support.

Available at <https://www.asetek.com/simsports/support/>



Please note the serial number on your product before contacting support. The serial number can be found on the bottom of the baseplate and written here for your convenience:



Serial Number	
Asetek Denmark A/S Skjoldet 20 9230 Svenstrup J Denmark www.asetek.com	 ASET EK RACING™

Symbols Used

Make sure you pay attention to all warnings and symbols on the product and packaging.

Indicates that minor to moderate injuries may be sustained if the instruction is not followed correctly



This indicates that the product could be damaged if the instruction is not followed correctly



Copyright

The content of this manual is protected by copyright and other international intellectual property laws. The contents of this manual or any parts thereof may only be made public, copied, modified, reproduced, translated with express written permission from Asetek. This manual or any parts thereof may only be published, transmitted, displayed, or made available to a third party with express written permission from Asetek SimSports®.

1. Introduction

Thank you for purchasing the Asetek Racing™ Initium™ Pedal Set. We strongly encourage you to read through this manual thoroughly in its entirety. The Pedals are a product made to fit every user.

1.1 Box Contents

The box contains the following components and accessories:

- Initium™ Pedal Set
- USB Type-C to USB Type-C cable (Two (2) meters)
- Allen Key, 2,5mm
- Pedal Manual
- Safety Information
- Product Warranty
- Hard brake spring
- Safety Information

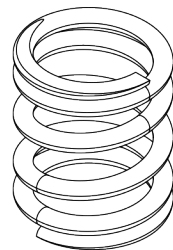
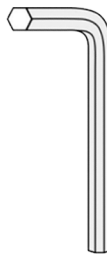
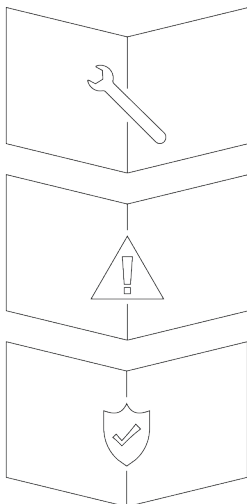
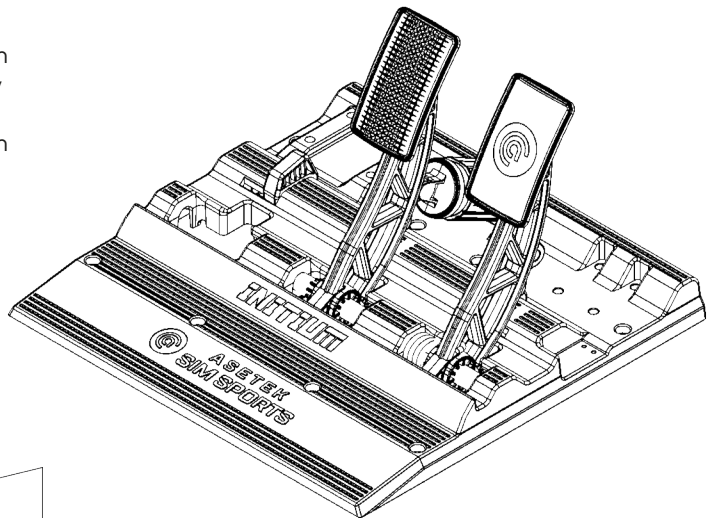

USB Type-C to USB Type-C



1.2 Videos

On the Asetek SimSports® YouTube channel, you can find tutorial videos which demonstrate numerous ways to set up and use your equipment.
<https://www.youtube.com/aseteksimsports>



1.3 Manual version

This manual is version 2.0.
You will always be able to find the latest version of the manual at:
www.asetek.com/simsports/knowledge-base/



1.4 Support & Contact

Should you stumble upon further questions that are not covered in this manual or any of our detailed instruction videos, we encourage you to contact our friendly support staff at
<https://www.asetek.com/simsports/support/>



2. Product

2.1 Intended Use

The pedals are designed to be used for racing simulation and simulate the feel of a race car. The pedals can be directly connected to any PC with a USB-C port or Asetek peripherals connector on the Asetek wheelbase. When using Xbox Series X|S, the pedals can be connected to the peripheral connector on the wheelbase. The Pedals are intended to be mounted in a sim racing cockpit or placed on the floor for "Floor Mode".



The pedals are intended for indoor use only



Recommended ages 15 and above



2.2 Compatibility

Platform(s)	PC (Windows 11), Xbox Series X S (with Xbox-licensed wheel and Xbox-ready wheelbase)
Games	You can find the list of supported games here: https://www.asetek.com/simsports/racehub/supported-games 



2.3 Reasonably Foreseeable Unintended Use

The following is considered misuse and may void the warranty:

- Use of adaptors or extension sets for cables;
- Use of other cables than provided with the product;
- Use in an environment that varies from or exceeds the given environmental conditions;
- Use that varies from or exceeds the given operating conditions;
- Failure to comply with the instructions in this manual;
- Failure to eliminate faults, malfunctions, or defects of the product that impose safety risks;
- Unauthorized removal or modification of parts or safety devices of the product;
- Use of spare parts or accessories that Asetek SimSports has not approved;
- Mounting and/or use of any parts in a vehicle;
- Adjusting pedal settings during operation;
- Operation in a flammable and/or explosive environment;

2.4 General Specifications

Dimensions (D x W x H)	370x263x253mm 14.57x10.35x9.96"
Weight	2.9kg 6,39lb
Materials	Glass-Fiber reinforced composite material
Sensor Types	Throttle: Hall sensor Brake: Hall sensor
Power Input	5V 100mA – Max. 500mW
Operating Temperatures	15°C to 35°C, room temperature
Max. Brake Force	Equivalent of 120-140 Kg

3. Product Overview

This section will give you a quick overview of the terminology of various parts and their position.

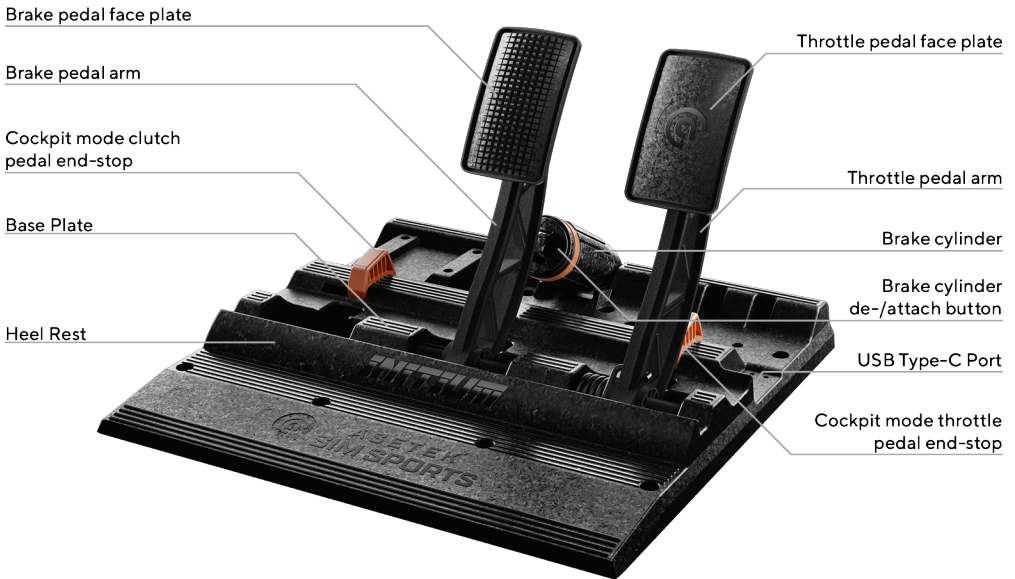

4. Getting Started

This section will teach you how to get your pedals set up and running. Later in the manual, you will learn more about fine-tuning and software.

4.1 Mounting Instructions

The pedals have two modes. In Floor mode, the pedal arms move to a 60-degree angle for comfort at a couch or a desk. In Cockpit mode, the pedal arms move to a 80-degree angle, and the pedal end-stop shortens the pedal travel for comfortable cockpit use.

4.1.1 Mounting Options

The pedals arrive in the box set to Floor mode.



NOTICE



Pedals need to be switched to the Cockpit Mode before mounting them in the cockpit. (see chapter 4.1.4)

The pedals are designed to withstand a great deal of braking force. Therefore, it is recommended that you install them on a very rigid base. Ideal conditions are a simracing cockpit (such as Initium™ 2 in 1 Cockpit) or a thick metal baseplate (we recommend 3 mm steel as a minimum). Alternatively, you can use the pedals on a floor, placing them against a wall to prevent movement. (We recommend trying pedals on different surfaces, such as short-haired carpet, to minimize the movement of the pedals)

4.1.2 Tools and Supplies Required for mounting to a cockpit

To mount the pedals in your cockpit, you will need the following tools and supplies:

- 1x Allen key, 2,5 mm (included)
- 1x Key wrench (not included)
- 8x M6 x 20 Socket cap screws (not included)
- 8x M6 nut (not included)
- 8x M6 A4 Washer (not included)



NOTICE

Mounting hardware included with the Initium™ 2 in 1 Cockpit.

4.1.3 Optional Tools for mounting to a cockpit

Depending on your cockpit and mounting preference, you may also need the following tools:

- Pencil or marker
- Screwdriver
- Power drill



4.1.4 Switching Modes

1. On the bottom side of the pedal set, in the Pedal support plates cutout, check for the icon of "Cockpit" or "Couch". (The visible one represents the mode your pedals are in)

 = Cockpit mode

 = Floor mode

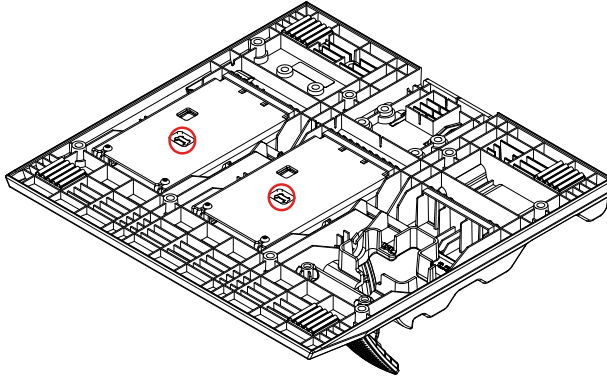

2. To change the mode, remove the brake cylinder from the pedal baseplate by pressing down on the top of the cylinder (facing the pedal arm) and pulling the brake cylinder out.

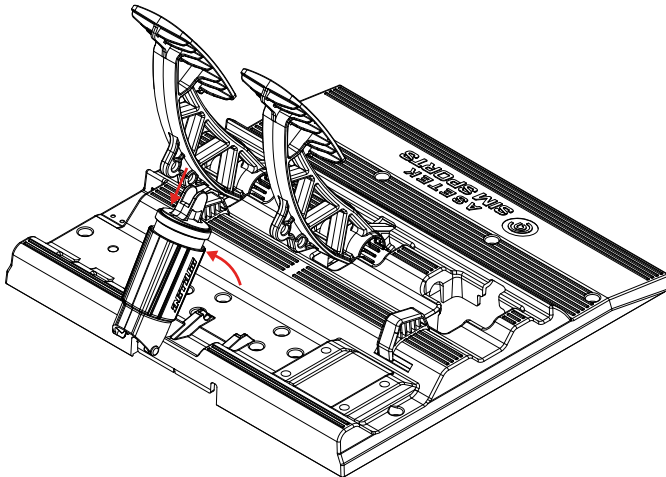

3. Turn the Pedals upside down. Unscrew the screws holding the Pedal Support Plate under both the Throttle and brake arm.

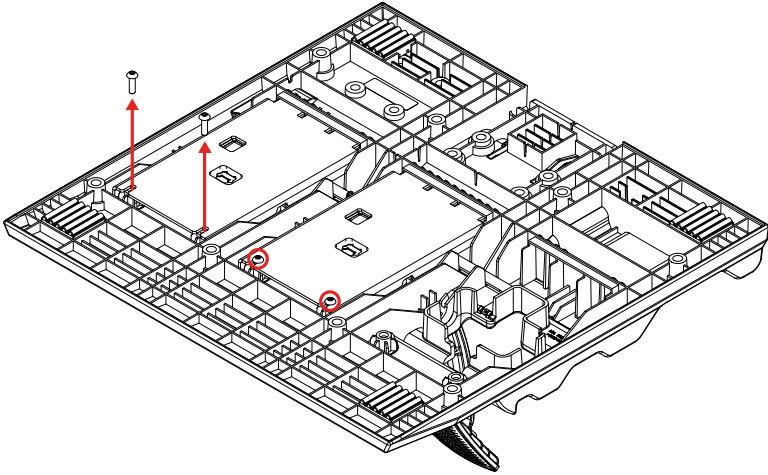

4. Remove the Pedal Support Plates.

 **NOTICE**

The icon facing the front of the pedals is the mode chosen and will be visible in the pedal support plate window.

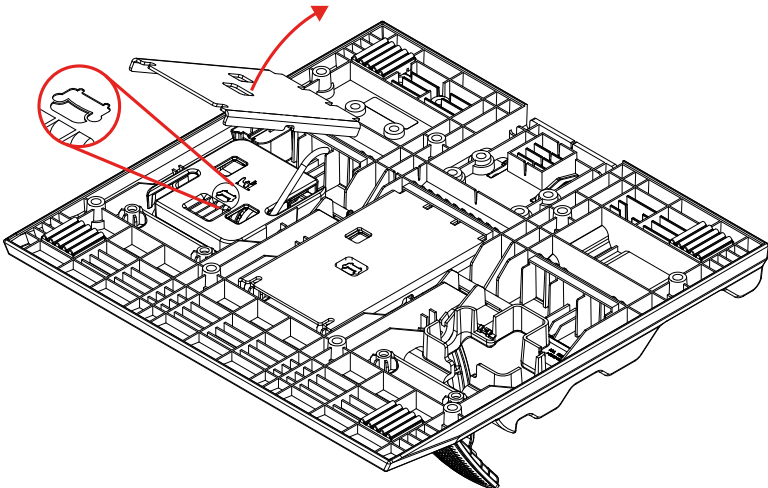

5. Pull out the Pedal angle conversion plate, turn it around (180°), and place it back in its designated spot. Repeat this for both pedals.

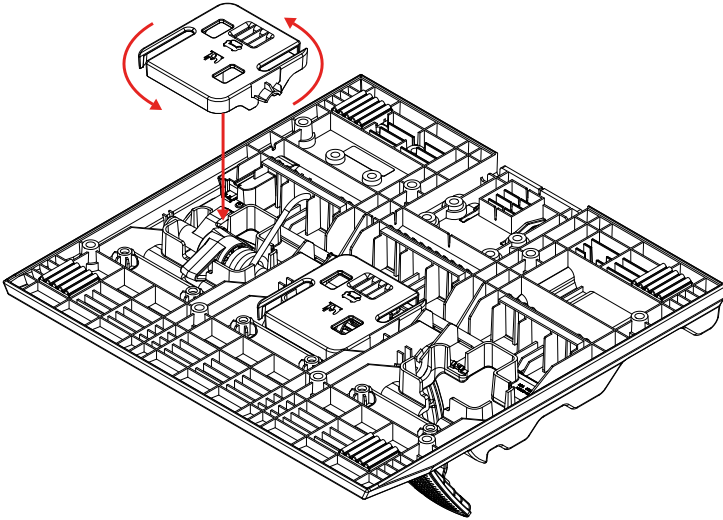

6. Attach the Pedal support plates back to the pedals and screw in the screws holding the Pedal support plate, that were removed in step 3.

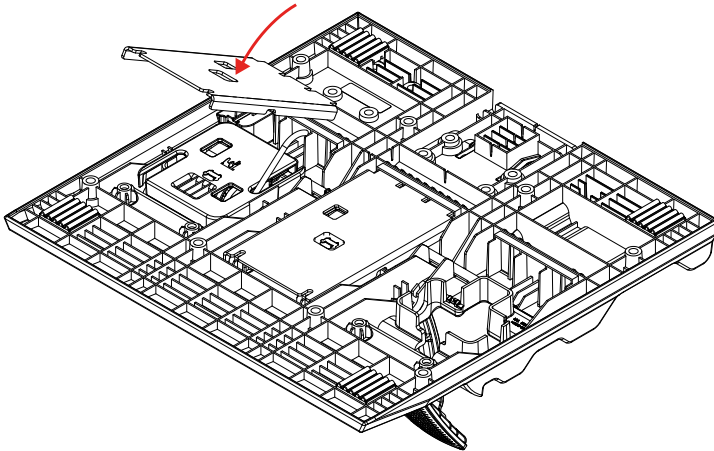

7. Turn the pedals back up, and move the orange tabs (pedal end stops).
 - a. For floor mode - position the pedal end stops to the left.
 - b. For cockpit mode - position the pedal end stops to the right.

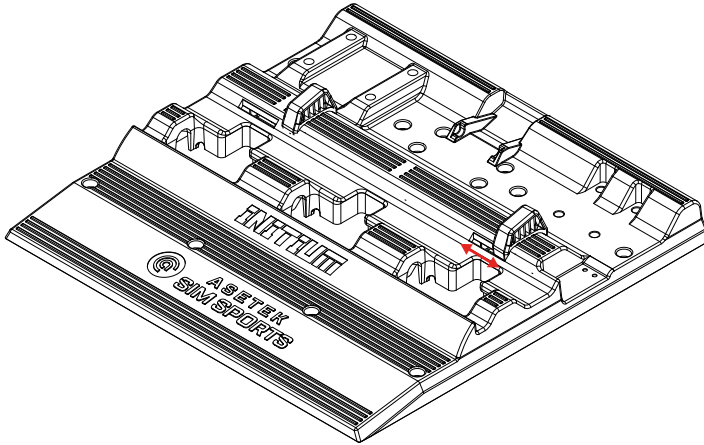

8. Reattach the brake cylinder to the pedal baseplate by placing it in either position a. or b. depending on which mode you have chosen. Place the back of the brake cylinder in a groove:
 - a. For floor mode - The groove at the edge of the pedal baseplate.
 - b. For cockpit mode - The groove closer to the pedal arm.

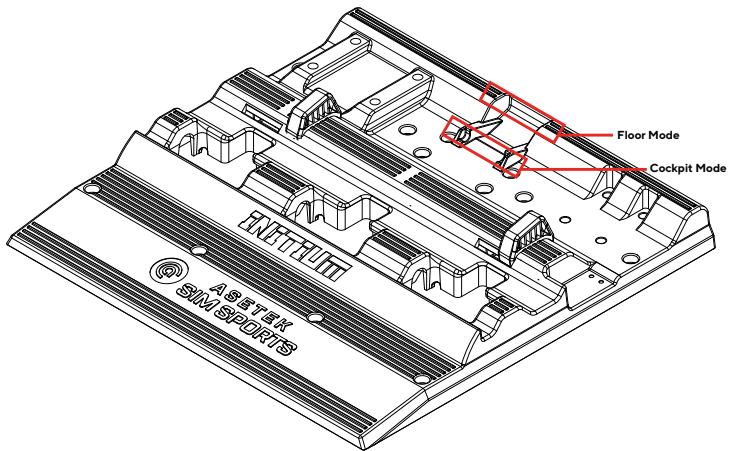

- Align the top of the brake cylinder with the upper hole on the back of the pedal arm, press the brake cylinder, and click it in place.

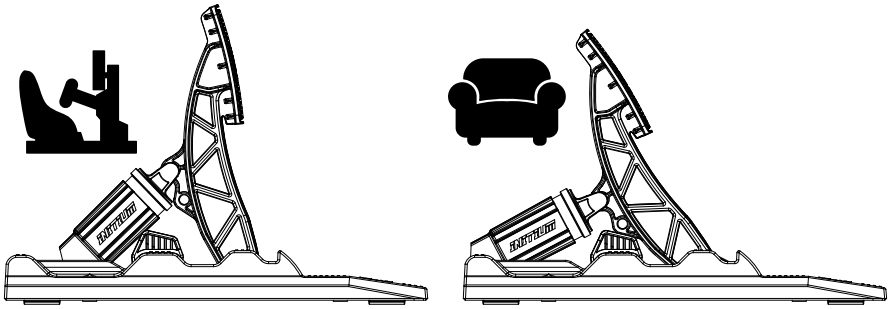

- Recalibrate your pedals in RaceHub. (see chapter 5.3)

4.1.4.a Floor Mode



The Pedals can be used without a sim racing cockpit. On the bottom side of the pedal set, in the support plates window, check for the icon of "Couch." In case the icon in the window represents "Cockpit," follow the steps in 4.1.4.

Simply place the pedals on the floor and enjoy the ride.

4.1.4.b Mounting to a Cockpit



The pedals have eight (8) mounting holes in fixed positions. As such, all adjustments to the positioning of the base must be handled by your cockpit.

The baseplate is designed to be used with M6 socket cap screws, and holes in your cockpit should be with 5mm diameter.

Mounting your pedals to a cockpit:

1. Set pedals to Cockpit Mode (follow steps in chapter 4.1.4)
2. Carefully remove dust and debris from the installation location.
3. Place the pedals in their designated spot in your cockpit.
Align the holes in the pedals to eight (8) existing mounting holes in your cockpit, if available.

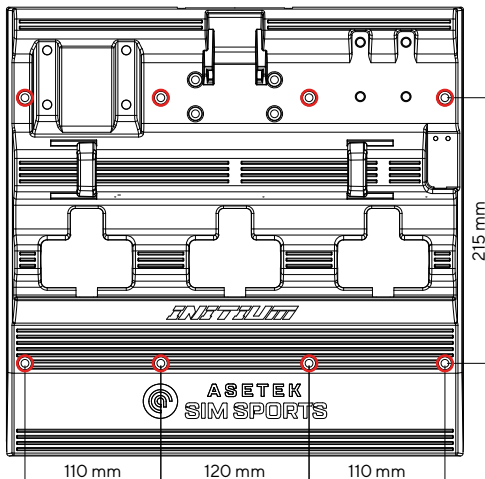

4. Mount the pedals to the existing holes. If there are no holes available or they do not line up, you can use the mounting hole schematics available on our knowledge base: <https://www.asetek.com/simspots/knowledge-base/manual-initium-pedals/>



Congratulations. You have successfully mounted your Pedals to your cockpit.
Enjoy the ride!

4.2 Adjusting the brake pedal hardness

The pedals come preinstalled with a soft brake spring. You get one extra spring in the box (a hard spring) if you wish your pedals to have a harder brake feel in the 2nd stage of braking. To change the spring, follow these simple steps:

1. Detach the brake cylinder from the pedals by pressing on the top of the brake cylinder (facing the pedal arm) and pulling out.

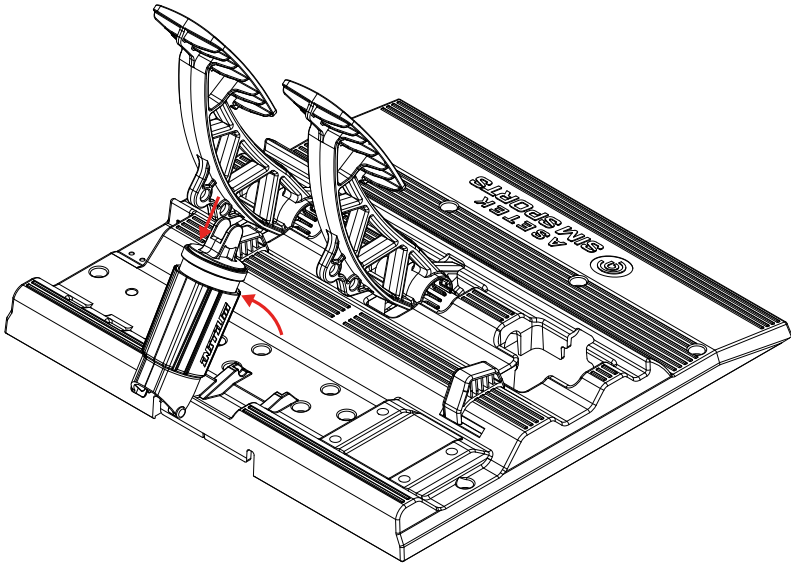

2. Compress the top of the brake cylinder and turn it 90°, this will unlock the spring inside.

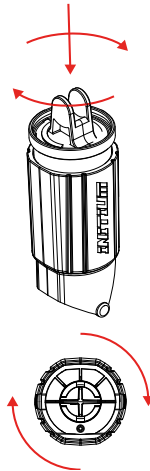

NOTICE

Follow the cross sign on the bottom of the brake cylinder. For the spring to come loose, the long side of the cross needs to align with the cutout.

3. Remove the components from the brake cylinder. Inside, there are 2 springs for 2 stages of braking. Remove the bottom spring and replace it with the hard one included in the box.

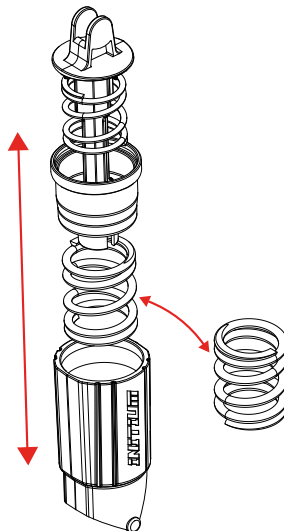

4. Reassemble the brake cylinder by aligning the longer side of the cross with the cutout on the bottom of the brake cylinder.

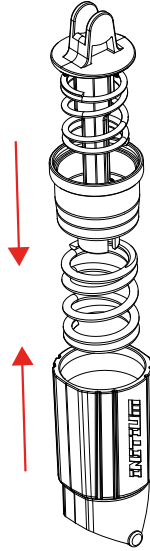

5. Press the top of the brake cylinder and turn it 90°, until the longer side of the cross safely latches inside the brake cylinder.

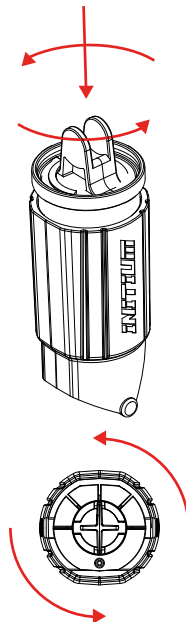

6. Reattach the brake cylinder to the pedal baseplate by placing it in either position a. or b. depending on which mode you have chosen. Place the back of the brake cylinder in a groove:
- a. For floor mode – The groove at the edge of the pedal baseplate.
 - b. For cockpit mode – The groove closer to the pedal arm.

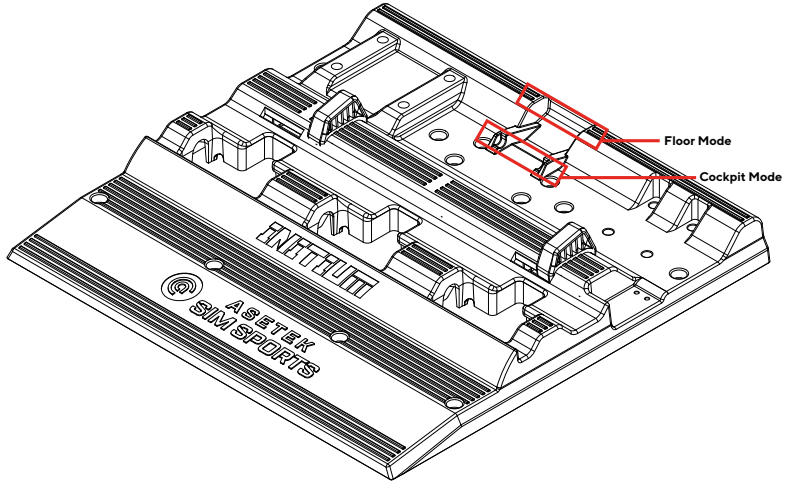

7. Align the top of the brake cylinder with the upper hole on the back of the pedal arm, press the brake cylinder, and click it in place .

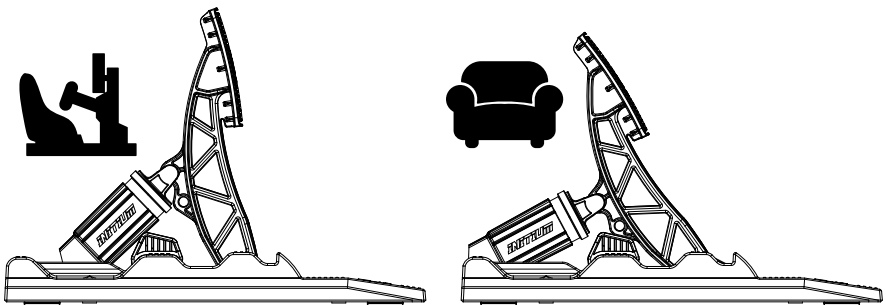

8. Recalibrate your pedals in RaceHub. (see chapter 5.3)

Congratulations. You have successfully changed the brake hardness. Enjoy the ride!

4.3 Connecting to your PC or Xbox Series X|S

In our relentless quest to make your experience as seamless and immersive as possible, we have gone to great lengths to simplify this process, too.

You will find a USB Type-C connection port next to the throttle pedal. We have opted for a single USB Type-C interface to make things simple to connect.

Note also the small zip tie holes on the top of the cover. We want to ensure that your cable is not strained and suggest you use the holes provided to insert a zip tie in, to alleviate any potential strain on the cable.

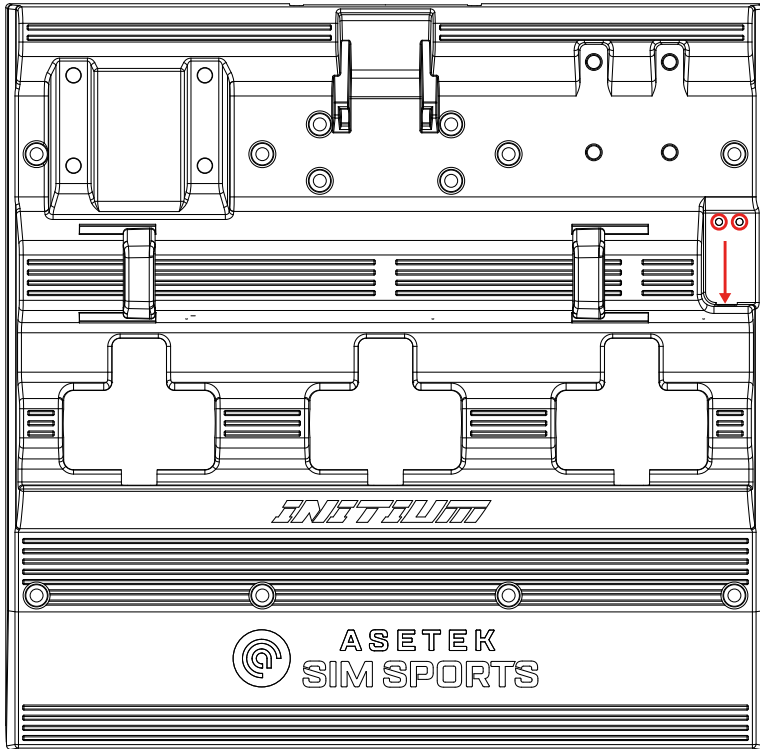

Connecting is now a simple task.

The pedals can be connected directly to any PC with a USB Type A or C port or to the Asetek peripherals hub on the wheelbase. When using Xbox Series X|S, connect the pedals to the peripheral hub on the wheelbase.

Proceed to install the RaceHub software and configure your pedals to your liking (See section 5. for instructions).

5. RaceHub™ Adjustments

All Asetek SimSports® and Asetek Racing™ products come with an extremely powerful yet easy-to-use piece of software that we have developed from the ground up. It is called RaceHub™ and will take care of your every need. RaceHub unlocks things you would not dare to dream of and is continuously updated.

5.1 RaceHub Download

RaceHub is available for download, in its newest version, on our website:
<https://www.asetek.com/simsports/racehub/>.



The RaceHub app is only available on PC. On Xbox Series X|S, RaceHub is accessed via RaceHub Link, directly on the Xbox-compatible wheel. Read more about RaceHub Link here:
<https://www.asetek.com/simsports/wp-content/uploads/2025/12/RaceHub-Xbox-Guide.pdf>



5.1.1 RaceHub Installation

After completing the download from our website, double-click the downloaded file to initiate the installation. Follow the on-screen instructions and install them in your desired directory. Once installed, open RaceHub using the shortcut on your desktop or in your programs folder.

5.1.2 RaceHub Updating

RaceHub will automatically notify you if there are available updates for the software. If you want to double-check, please go to www.asetek.com/simsports/racehub and download the newest version. RaceHub has a built-in feature that allows you to update the firmware on your devices automatically.

5.2 Introduction

RaceHub allows you to make a plethora of adjustments to your Pedals. It will allow you to adjust pedal maps, calibrate your pedals, and much more.

Everything is available in a highly user-friendly interface that allows for quick and easy customization that not only gives you complete control but does it in a manner where you are constantly in focus – teaching you everything you need to know to become a power user and expert sim racer.

The settings you choose in RaceHub will be applied to all the supported games found in section 2.2, “Compatibility,” ensuring maximum performance and precision!

5.3 Pedal Calibration

To ensure your pedals are as precise as possible, run the pedal calibration wizard in RaceHub. You can choose either automatic calibration or you can choose to calibrate the pedals manually through a series of activations.

Automatic Calibration:

1. Navigate to the pane in RaceHub called Calibration.
2. Push the Automatic Calibration button.

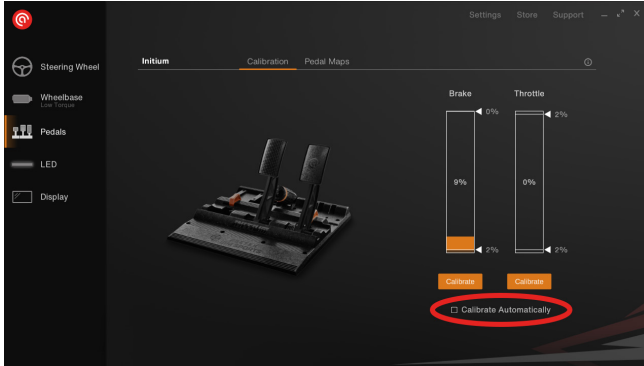

Done! Your calibration will carry over into all the supported games.

Manual Calibration:

1. Navigate to the pane in RaceHub called Calibration.
2. Push the Calibrate button.

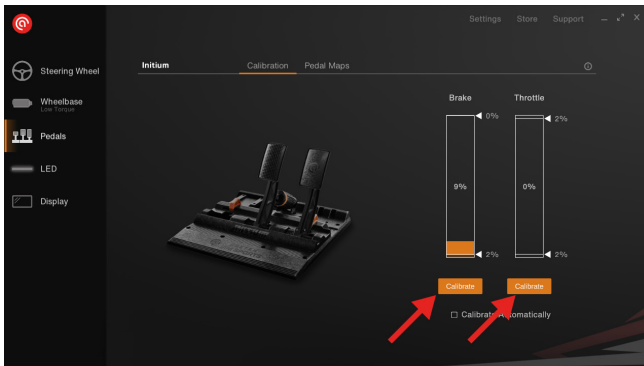

3. Follow the on-screen instructions.

Done! Your calibration will carry over into all the supported games.

5.4 Deadzone Adjustments

In RaceHub, you will be able to set both top and bottom deadzones on all your pedals. A bottom deadzone allows you to slightly activate your pedal without engaging the brake. For example, if you rest your foot on the pedal.

A top deadzone allows you to modify the point of full activation. In the case of a throttle pedal, this would allow you to reach 100% throttle before your throttle pedal reaches full activation and the mechanical pedal stop. This preference is individual and generally done by a race engineer before the car goes on track. RaceHub allows you to customize it fully, and we strongly encourage you to do it as well, not to lose potential speed and lap time.

The top and bottom deadzones can be adjusted using these sliders marked here:

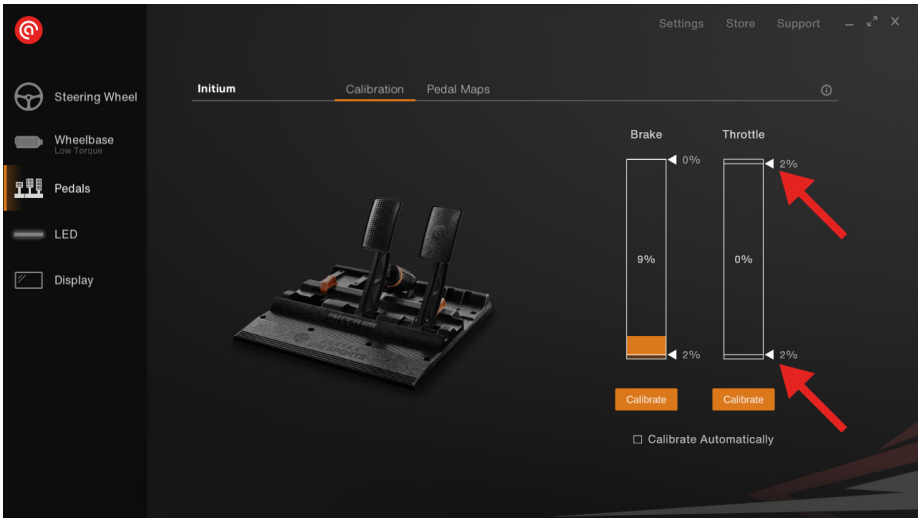

We suggest the following settings for deadzone when using the pedals, which is how it is calibrated from our factory.

Throttle:

- Top: 2%
- Bottom: 2%

Brake:

- Top: 0%
- Bottom: 2%

5.5 Maximum Brake Force Adjustment

RaceHub allows you to calibrate your brake with accurate measurements (with a maximum supported force of 140 kg). However, should you require less pressure to reach what the simulator is recognizing to be 100% brake application, you can calibrate whichever force you want to equal 100%.

5.6 Custom Pedal Mapping

One of the great features of RaceHub is the ability to map the curves of your pedals precisely to your liking. In most racing simulator pedals, you will find a 1:1 relation between the amount pressed on the pedal and the response in-game. This is not how things work in real racing – so why should it be this way in your sim cockpit? The answer is, it should not, and our pedal maps help you avoid just that.

We have made a few preset curves that mimic typical scenarios, but the RaceHub also allows complete customization of your pedal curves. Click, drag and drop – it is that simple!

As we briefly mentioned, a real race car will not have a linear throttle response. An example is the Audi R8 LMS GT3, which has less activation of the throttle at the beginning of the pedal activation, increasing as you progress through the travel. Similarly, you can adjust your curves based on your driving conditions—all in search of ultimate performance.

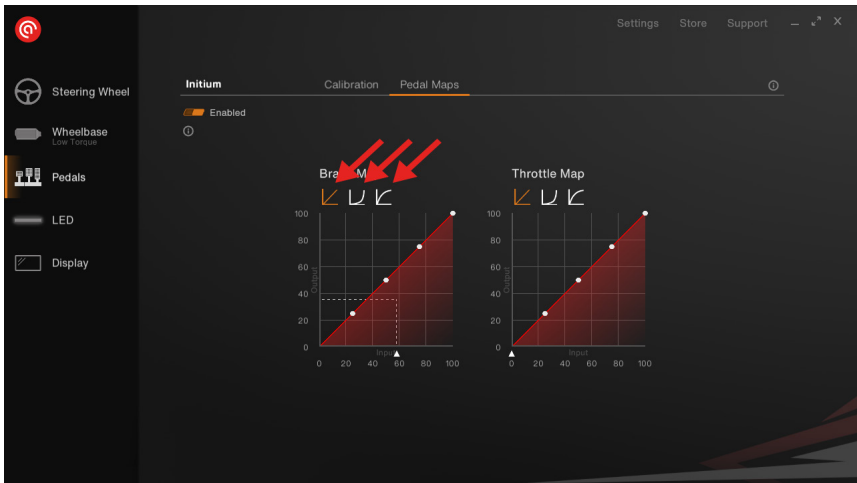

Please note that RaceHub custom pedal maps work best when they are used exclusively and without the use of potential in-game settings. If your preferred simulator game offers a pedal mapping feature, we highly suggest you live it as linear and instead use the functionality in RaceHub.

6. Compatible products

Asetek SimSports offers compatible products to increase your experience driving with pedals even further. This includes all Initium™ upgrade kits available for the Asetek Racing™ Initium™ Pedal Set, for even more realistic immersion. These can be purchased at Asetek SimSports' webshop or at Asetek SimSports authorized dealer.

7. Maintenance

Owning a set of Asetek pedals means a minimum of maintenance needed. However, we do have a few suggestions that will help you keep your pedals feeling supreme.

7.1 Throttle Maintenance

We suggest you clean the throttle at regular intervals (6 months) with a soft, dry, clean cloth.

NOTICE

Do not use water or cleaning agents to clean the product

7.2 Brake Maintenance

We suggest cleaning the brake at regular intervals (3 months or 100 hours of use) with a soft, dry, clean cloth.

NOTICE

Do not use water or cleaning agents to clean the product

7.3 Spare Parts

We strongly advise you only use original Asetek SimSports spare parts. Failure to do so will void your warranty.

If you have questions, or do not know if you have an original part, please refer to <https://www.asetek.com/simsports/> or consult the Asetek SimSports support. (See chapter 1.4)

8. Troubleshooting

Sometimes unforeseen issues occur. But do not worry, we are here to help.

If you are having issues we suggest consulting the FAQ and troubleshooting section of our Knowledge base at: <https://www.asetek.com/simspots/knowledge-base/>



If you are not able to find a solution on the FAQ please consult our friendly and knowledgeable support staff (See chapter 1.4).

9. Safety

- The device must not be exposed to rain or humidity to avoid the risk of fire and electric shock.
- We strongly advise you not to drive a vehicle immediately after racing simulation games.
- This product is not intended for children under the age of 15 years.
- Contains small pieces. Danger of swallowing!
- Extended periods of gaming may cause health risks. Take a break of 5 minutes every 20 minutes, and do not play for more than 2 hours per day.
- Keep hands, fingers, hair, clothing, and jewelry away from the product when in use.
- Only one person may use the product at any given time. Keep other people away from the product when in use.
- Keep the product and the power cord away from children and pets.
- This product contains components that the user cannot repair. Opening parts of the product may compromise the safe use of the product and will void the warranty.
- Do not disassemble this product beyond what is described in the product manual.
- Avoid eye contact with the lubrication grease and wash hands thoroughly after adjustment.
- Make sure the mounting of the pedal set and all parts are secured tightly before use.
- Check frequently that the pedals are mounted properly.

10. De-commissioning & Sustainability

At Asetek we are fiercely committed to making the world a sustainable place. You can read more about Asetek's sustainability efforts, including our sustainability reports, here: www.asetek.com/company/sustainability



This symbol indicates that this product should not be thrown away with other household waste throughout the EU. To prevent possible harm to the environment or human health by uncontrolled waste disposal, you are responsible for recycling it so that it can promote the sustainable reuse of raw materials. To return your used product, you can use the regular return and collection systems.

10.1 Packaging

All packaging is to the extent possible, made of paper and cardboard. All our cardboard and paper products are labeled with the FSC mark, ensuring maximum reusability and that the forests are sustainably forested. Furthermore, we regularly check our vendors to make sure they are upholding their commitments.

About FSC: www.fsc.org/en/fsc-labels

If you need to dispose of your packaging, please use the appropriate paper waste stream in your country, to dispose of the packaging. Naturally, we hope you want to keep it around – we are quite proud of it.

10.2 Product

Asetek SimSports® and Asetek Racing™ is committed to making products that will last. However, we also know that sometimes things break, and that should not result in a scrap and forget, producing even more e-waste to our planet. If you feel uncertain about how to recycle any Asetek SimSports® or Asetek Racing™ product, we suggest getting in touch with our dedicated customer support team, who will happily help you.

Contact support (See chapter 1.4)

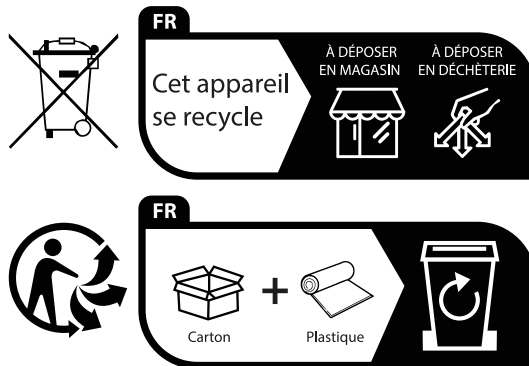

Points de collecte sur www.quefairedemesdechets.fr
Privilégiez la réparation ou le don de votre appareil !

11. Declaration of conformity

We Asetek, as the manufacturer, declare that products from the brand Asetek are tested according to all relevant CE standards/regulations and passed all tests.

The complete Declaration of Conformity can be found and downloaded via:
<https://www.asetek.com/simsports/declarations/>

***WHERE REAL
RACING STARTS***